

MX-10 Extreme

user manual

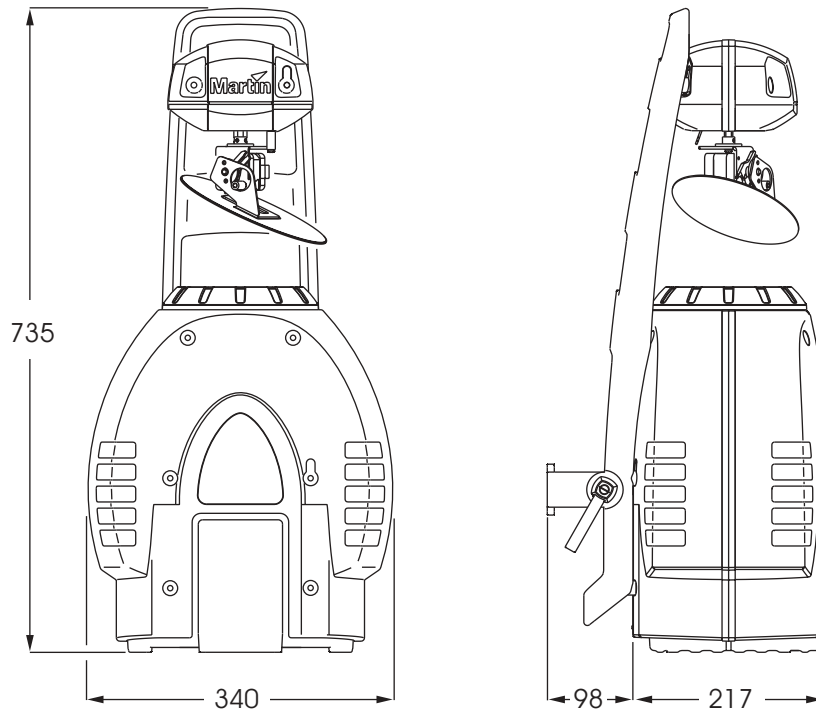

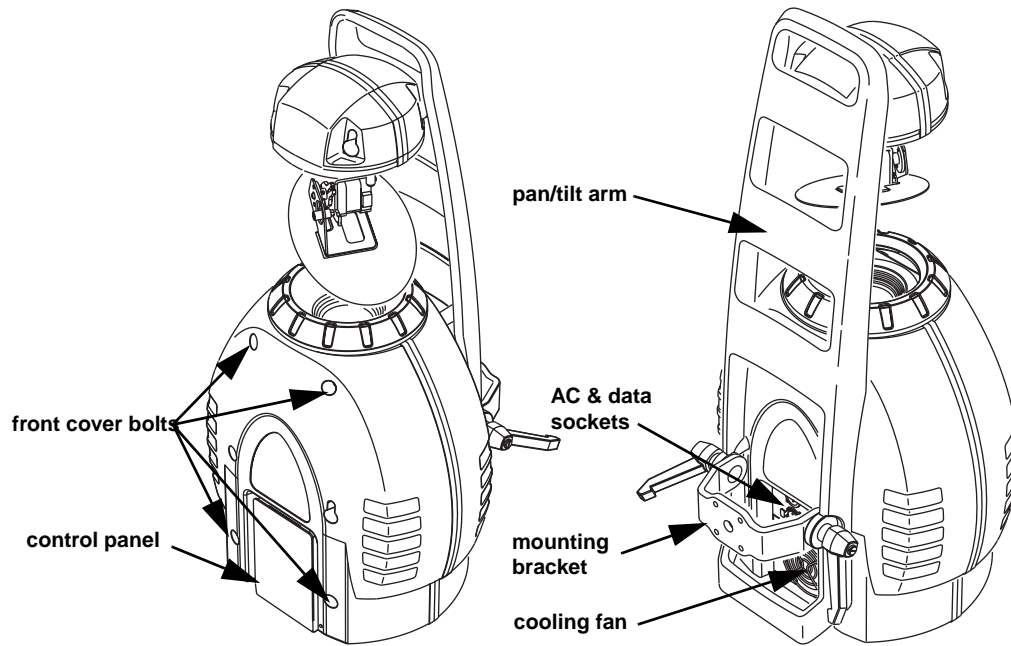

©2002 Martin Professional A/S, Denmark.

All rights reserved. No part of this manual may be reproduced, in any form or by any means, without permission in writing from Martin Professional A/S, Denmark.

Printed in Denmark.

P/N 35000117, Rev. E

Introduction	4
Features	4
About this manual	4
Safety	5
Safety precautions	5
Setup	6
Unpacking	6
Lamp installation	6
AC power	8
Installation	9
Connecting the serial data link	10
Control Panel	11
Menu navigation	11
Address selection	11
Tailoring performance	12
Information readouts	13
Test and service utilities	13
DMX-512 control	15
Lamp power	15
Effect position	15
Speed control	16
Optical configuration	17
Gobos	17
Color filters	19
Prism	20
Service	21
Lamp replacement	21
Mirror replacement	21
Cleaning	21
Lubrication	22
Replacing fuses	22
Updating software	23
DMX protocol	24
Control menu	28
Error messages	31
Troubleshooting	32
PCB connections	33
Specifications - MX-10	34

INTRODUCTION

Features

Thank you for selecting the Martin MX-10 Extreme. Some of the many features include:

- efficient, 2000 hour, 250 watt discharge lamp
- 12 interchangeable dichroic colors
- 8 interchangeable indexed-rotation gobos
- interchangeable 3-facet rotating prism
- motorized focus
- full-range dimming
- fast blackout and strobe effects
- fast and accurate 16-bit mirror movement
- advanced low-noise motor control
- coated optics
- user-installable firmware
- switch-selectable power supply settings
- power factor correction
- integrated mounting bracket and floor stand
- easy-to-clean cooling fan

About this manual

Please check the Martin web site at <http://www.martin.dk> for the latest product software and documentation.

Comments or suggestions regarding this document may be e-mailed to service@martin.dk or posted to

Martin Professional A/S
Olof Palmes Allé 18
DK-8200 Aarhus N, Denmark
Attn: Service Department

Please review the important safety precautions in this manual before installing and operating the fixture.

SAFETY

Warning! *This product is for professional use only. It is not for household use.*

This product presents risks of lethal or severe injury due to fire and heat, electric shock, ultraviolet radiation, lamp explosion, and falls. **Read this manual** before powering or installing the fixture, follow the safety precautions listed below and observe all warnings in this manual and printed on the fixture. If you have questions about how to operate the fixture safely, please contact your Martin dealer or call the Martin 24-hour service hot line at +45 70 200 201.

Safety precautions

PROTECTION FROM ELECTRIC SHOCK

- Disconnect the fixture from AC power before removing or installing the lamp, fuses, or any part, and when not in use.
- Always ground (earth) the fixture electrically.
- Use only a source of AC power that complies with local building and electrical codes and has both overload and ground-fault protection.
- Do not expose the fixture to rain or moisture.
- Refer any service operation not described in this manual to a qualified technician.

PROTECTION FROM UV RADIATION AND LAMP EXPLOSION

- Never operate the fixture with missing or damaged lenses and/or covers.
- When replacing the lamp, allow the fixture to cool for at least 15 minutes before opening the fixture or removing the lamp. Protect your hands and eyes with gloves and safety glasses.
- Do not stare directly into the light. Never look at an exposed lamp while it is lit.
- Replace the lamp if it becomes defective or worn out, or before usage exceeds the maximum service life.

PROTECTION FROM BURNS AND FIRE

- Never attempt to bypass the thermostatic switch or fuses. Always replace defective fuses with ones of the specified type and rating.
- Keep all combustible materials (for example fabric, wood, paper) at least 0.1 meter (4 inches) away from the fixture. Keep flammable materials well away from the fixture.
- Do not illuminate surfaces within 0.3 meters (12 inches) of the fixture.
- Provide a minimum clearance of 0.1 meters (4 inches) around fans and air vents.
- Never place filters or other materials over the lens or mirror.
- The exterior of the fixture can get very hot. Allow the fixture to cool for at least 5 minutes before handling.
- Do not modify the fixture or install other than genuine Martin parts.
- Do not operate the fixture if the ambient temperature (T_a) exceeds 40° C (104° F).

PROTECTION FROM INJURY DUE TO FALLS

- When suspending the fixture, verify that the structure can hold at least 10 times the weight of all installed devices.
- Verify that all external covers and rigging hardware are securely fastened and use an approved means of secondary attachment such as a safety cable.
- Block access below the work area whenever installing or removing the fixture.

SETUP

Unpacking

The MX-10 Extreme comes with:

- MSD 250/2 lamp (not installed)
- 3-meter, 3-wire IEC power cable
- user manual

Important! *Cut and remove the cable tie from the tilt motor bracket before operating.*

The packing material is carefully designed to protect the fixture during shipment - always use it or a custom flight case to transport the fixture.

Lamp installation

A lamp must be installed prior to initial operation.

COMPATIBLE LAMPS

A Philips MSD 250/2 lamp is included. The MX-10 Extreme lamp options are shown in the table below. *Installing any other lamp may damage the fixture.*

Lamp	Average life	Replace before	Color Temp.	Output	P/N
Osram HSD 250	2000 hr	2500 hr	6000K	68 lm/W	97010103
Philips MSD 250/2	2000 hr	2200 hr	6500K	72 lm/W	97010100
Philips MSD 200	2000 hr	2200 hr	5600K	67 lm/W	97010106

Table 1: Lamp comparison

TO INSTALL A LAMP

WARNING! When replacing the lamp, disconnect the fixture from AC power and allow the lamp to cool for at least 15 minutes before proceeding. Wear safety goggles to protect your eyes.

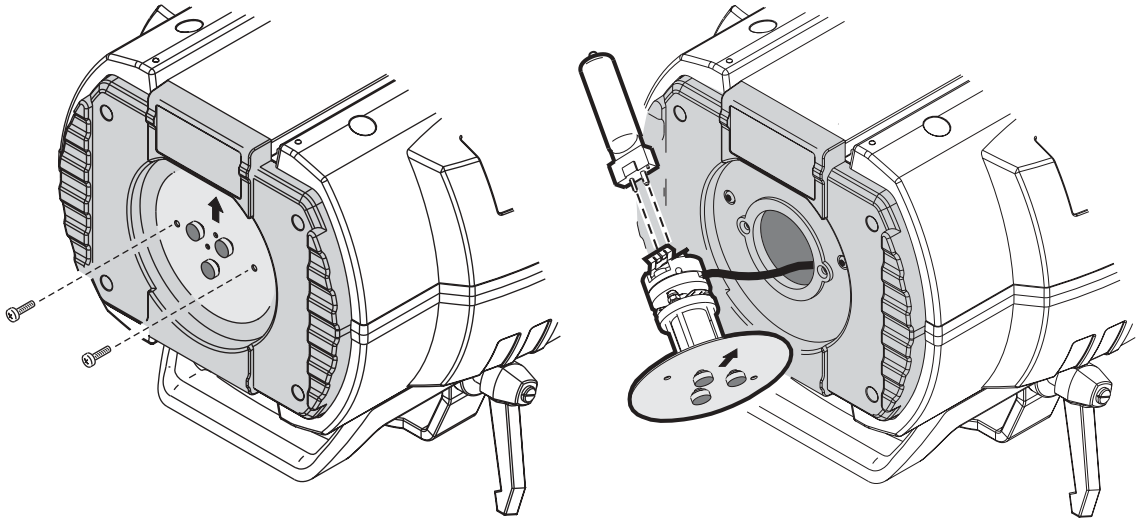
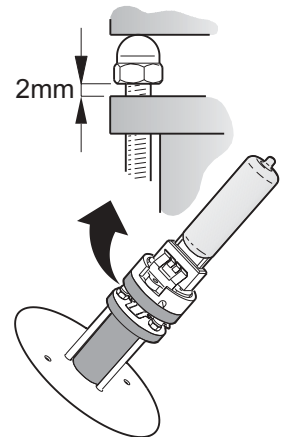

Figure 1: Lamp installation

- 1 Remove the 2 screws labelled "Lamp replacement" and pull out the lamp socket.
- 2 If changing the lamp, remove the old lamp from the socket.
- 3 Pre-adjust the lamp socket by turning the 3 lamp adjustment screws to the middle of their range. There should be 2 mm between each cap nut and the fixed disk.
- 4 Holding the new lamp by its ceramic base (do not touch the glass), align the small pin on the lamp with the small hole in the socket and insert the lamp squarely. Make sure that the 4 small projections on the base contact the face of the socket.
- 5 Clean the glass bulb with the cloth supplied with the lamp, particularly if your fingers touched the glass. A clean, lint-free cloth wetted with alcohol may also be used.
- 6 Insert the tip of the lamp into the fixture with as little twist in the lamp wires as possible. When the base of the lamp is inside the fixture, turn the lamp assembly so that the arrow points towards the control panel. Carefully locate the reflector opening, which is deep within the lamp chamber, and fully insert the lamp.
- 7 Align the screw holes and fasten the lamp access plate with 2 screws.
- 8 If replacing the lamp, reset the lamp hour and lamp strike counters as described on page 13.
- 9 Strike the lamp (after setup is complete) and adjust it for optimum performance by turning the 3 adjustment screws one at a time until the brightest part of the beam is centered.



AC power

Warning! For protection from electric shock, the fixture must be grounded (earthed). The power supply shall have overload and ground-fault protection.

Important! Verify that power supply settings match the local AC supply before use.

The MX-10 Extreme is factory configured for 230 V / 50 Hz operation. If your AC power supply is different, the fixture must be configured for the local voltage and frequency. Always use the voltage settings that are equal to or next highest to your AC supply.

TO CONFIGURE FOR LOCAL AC POWER

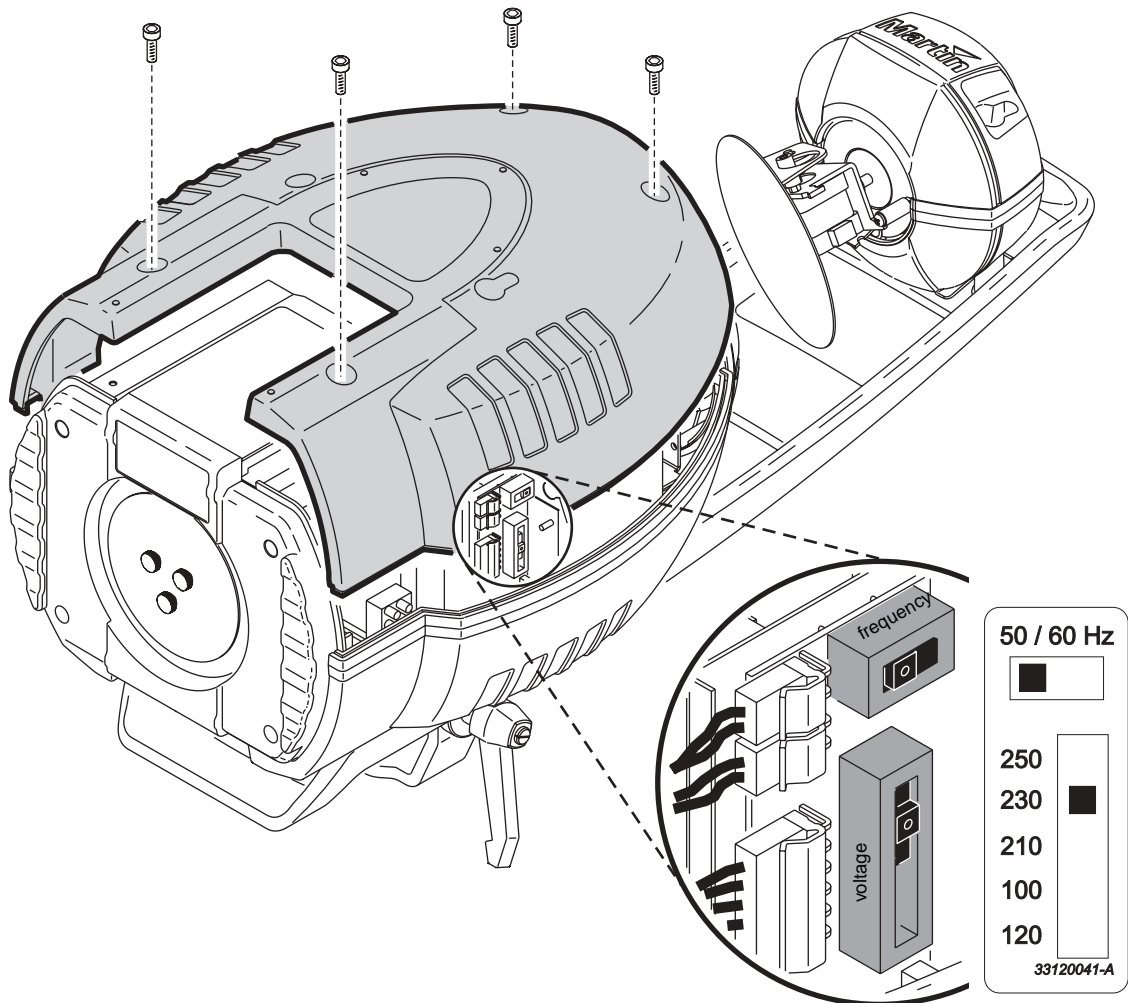

Figure 2: Power supply settings

- 1 Disconnect the fixture from power.
- 2 Remove the 4 cover screws with a 5 mm hex key. Lift off the front cover.
- 3 Locate the selection switches and the settings label, which is by the color wheel. Move the voltage switch to the setting that is equal to or higher than the local AC voltage. If your voltage falls between 2 settings, always select the higher voltage. For example, if the AC voltage is 215 V, use the 230 V setting instead of 210 V.
- 4 Move the frequency switch to the setting that matches the local AC frequency: 50 or 60 Hz.
- 5 Replace the cover.

TO INSTALL A PLUG ON THE POWER CABLE

The power cable must be fitted with a grounding-type cord cap that fits your power distribution system. Consult an electrician if you have any doubts about proper installation.

- Following the cord cap manufacturer's instructions, connect the yellow and green wire to ground (earth), the brown wire to live, and the blue wire to neutral. The table below shows some pin identification schemes.

Wire	Pin	Marking	Screw color
brown	live	"L"	yellow or brass
blue	neutral	"N"	silver
yellow/green	ground		green

Table 2: Plug wiring

TO APPLY POWER

Warning! *The power cables must be undamaged and rated for the electrical requirements of all connected devices.*

Important! *Powering through a dimmer system can damage the fixture.*

- 1 Verify that the supply cable is undamaged and rated for the current requirements of all connected devices.
- 2 Plug the prepared power cable into the AC socket and a grounded AC power supply.

AC input & fuse holder

Data input

Data output

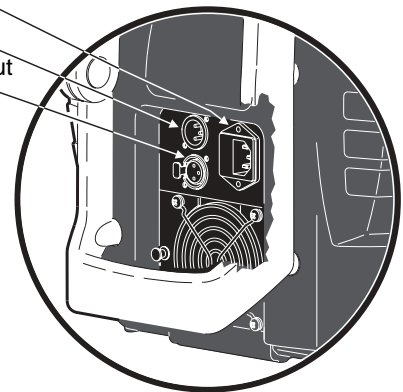

Installation

LOCATION AND ORIENTATION

The MX-10 Extreme may be installed in any orientation. It can be fastened directly to a suitable surface, hung with a rigging clamp, or placed directly on a level surface.

For safe operation, install the MX-10 Extreme in a location where

- the mirror is at least 0.3 meters (12 inches) away from any illuminated surface
- the fixture is at least 0.1 meters (4 inches) away from combustible materials
- the fixture is protected from rain and moisture
- there is at least 0.1 meters (4 inches) clearance around the fan and control panel
- there are no flammable materials nearby

TO RIG OR MOUNT THE MX-10 EXTREME

Warning! *Block access below the work area before proceeding.*

Warning! *Always use a secure means of secondary attachment.*

- 1 If using a rigging clamp (not included), verify that it is undamaged and can bear at least 10 times the fixture's weight. Bolt the clamp securely to the bracket with a grade 8.8 (minimum) M12 bolt and lock nut, or as recommended by the clamp manufacturer, through the 13 mm hole in the center of the mounting bracket.
- 2 If fastening the fixture directly, verify that the hardware (not included) and mounting surface can bear at least 10 times the fixture's weight. The four 6.2 mm holes and/or the 13 mm hole in the mounting bracket may be used to fasten the fixtures.
- 3 Verify that the structure can support at least 10 times the weight of all installed fixtures, clamps, cables, auxiliary equipment, etc.
- 4 Working from a stable platform, clamp or fasten the fixture to the structure.

- 5 Install a safety cable that can hold at least 10 times the weight of the fixture through/over the support and anywhere through the aluminum pan/tilt arm that does not interfere with mirror movement.
- 6 Loosen the swivel locks and tilt the fixture to the desired angle. Turn the swivel locks clockwise to tighten. When a handle reaches its limit, pull it out, turn counterclockwise, release, and continue tightening.
- 7 Verify that the fixture meets the location requirements listed previously.

Connecting the serial data link

The MX-10 Extreme has locking 3-pin data input and output sockets that are wired for use with DMX devices with pin 1 to shield, pin 2 to cold (-) and pin 3 to hot (+). As some devices have 5-pin connectors, or 3-pin connectors with reversed polarity on pins 2 and 3, the following adaptor cables may be required.

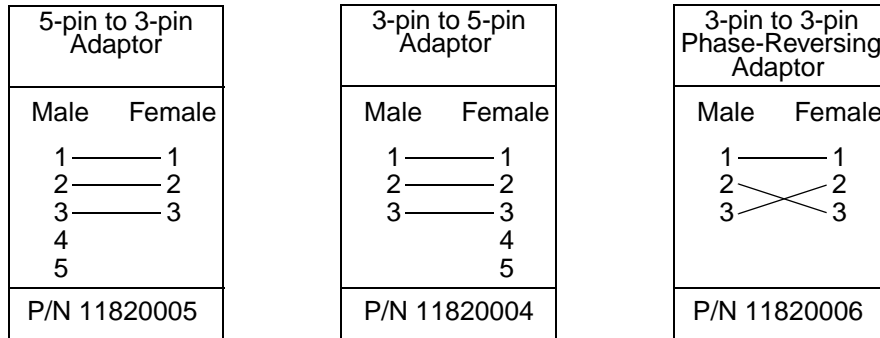

Figure 3: Cable adaptors

- 1 Connect the controller's output to the fixture's data input. For a DMX controller with 5-pin output, use a cable with a 5-pin male and a 3-pin female XLR connector.
- 2 Connect the output of the fixture closest to the controller to the input of the next fixture. If connecting a fixture with pin 3 hot to a fixture with pin 3 cold, use a phase-reversing adaptor.
- 3 To terminate the link, insert a male 120 Ω XLR termination plug in the output of the last fixture.

AC input & fuse holder

Data input

Data output

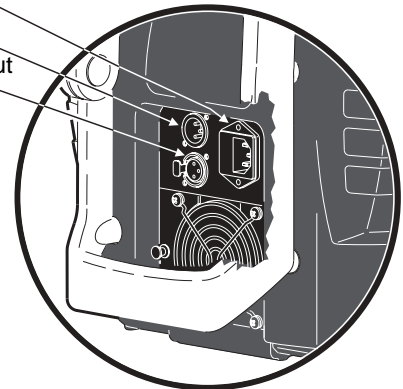

TIPS FOR BUILDING A SERIAL LINK

- Use shielded twisted-pair cable designed for RS-485 devices: standard microphone cable cannot transmit DMX data reliably over long runs. For links up to 300 meters (1000 ft.) long, you can use 24 AWG, low capacitance, 85-150 ohm characteristic impedance, shielded cable with 1 or more twisted pairs. For runs up to 500 meters (1640 ft.) use 22 AWG cable. Use an amplifier if the serial link exceeds 500 meters.
- Never use a “Y” connector to split the link. To split the serial link into branches use a splitter such as the Martin 4-Channel Opto-Isolated RS-485 Splitter/Amplifier.
- Do not overload the link. Up to 32 devices may be connected on a serial link.
- Terminate the link by installing a termination plug in the output socket of the last fixture on the link. The termination plug, which is simply a male XLR connector with a 120 ohm, 0.25 watt resistor soldered between pins 2 and 3, “soaks up” the control signal so it does not reflect back down the link and cause interference. If a splitter is used, terminate each branch of the link.

CONTROL PANEL

You set the address and personalities, read out data, and execute service utilities from the control panel. Settings can also be changed remotely via the serial link with the Martin MP-2 uploader.

There are four small symbols that can appear in the control panel display:

Tick/check	Power is on and the fixture is ready
Disc	The fixture is writing to memory. Do not power off the fixture while this symbol is lit.
Network	The fixture is receiving DMX
Wrench/spanner	Error

Menu navigation

See also the control menu table starting on page 28.

The DMX address and any error messages are displayed after the fixture resets. To enter the menu, press [menu]. Use the [up] and [down] keys to move within the menu. To select a function or submenu, press [enter]. To escape a function or menu, press [menu].

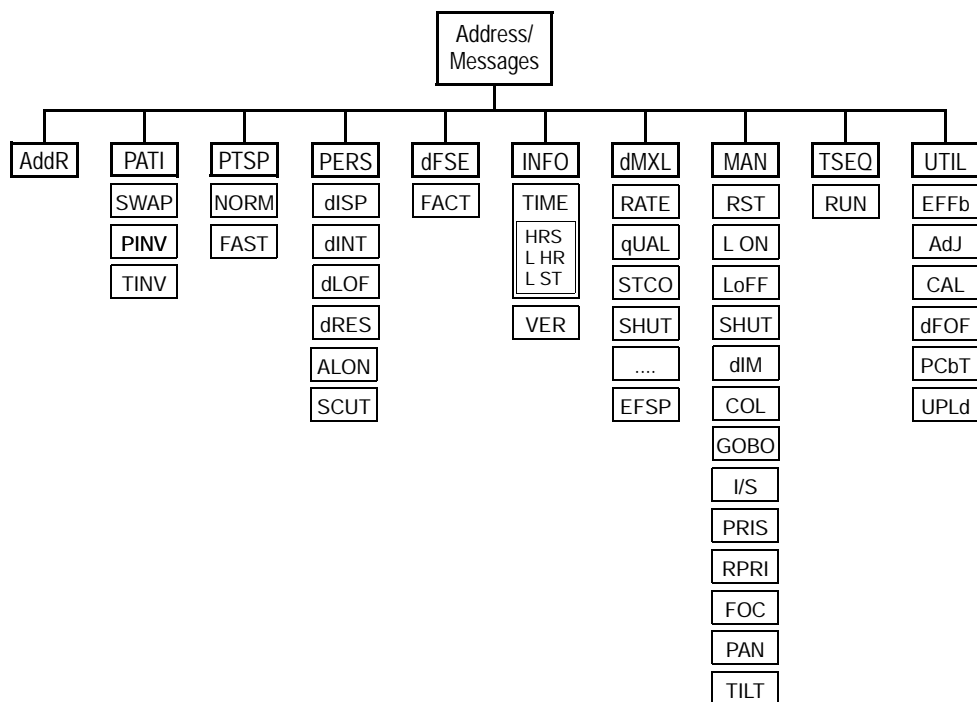

Figure 4: MX-10 Extreme menu

Address selection

The MX-10 Extreme requires 13 channels for DMX control. The address, also known as the start channel, is the first channel used to receive instructions from the controller. For independent control, each fixture must be assigned its own

address and non-overlapping control channels. Two MX-10 Extremes can share the same address if they are to respond identically; they will receive the same instructions and individual control will not be possible.

TO SET THE DMX ADDRESS

- 1 Apply power to the MX-10 Extreme. Press [menu] to enter the main menu.
- 2 Select AddR using the [up] and [down] keys. Press [enter].
- 3 Select an address (start channel) from 1 to 500 using the [up] and [down] keys. Press [enter]. Press [menu] to return to the main menu.

Tailoring performance

MOVEMENT

The MX-10 Extreme provides the three options for optimizing movement to suit different applications.

PATI, the pan and tilt invert menu, allows you to swap the pan and tilt channels (SWAP>ON), invert pan movement (PINV>ON), and invert tilt movement (TINV>ON). These options can be useful in situations where you want some fixtures to mirror the performance of others with the same DMX address, or when fixtures are not oriented as programmed.

PTSP, the pan/tilt speed menu, provides 2 settings: FAST and NORM. NORM is best for most applications. FAST provides better performance in applications where speed is most important.

SCUT, the shortcuts setting, determines whether the color and gobo wheels scroll past open when changing positions. When set to ON, the wheels can “take a shortcut” and scroll through open when this is the shortest path to the next position. The wheels do not scroll past open when SCUT is set to OFF.

DISPLAY

The display menu (PERS>dISP) determines whether the display remains lit or not. Select ON to have the display remain lit, or OFF to extinguish the display two minutes after the last key press.

To flip the display for easier reading, press [up] and [down] simultaneously.

The display intensity setting (PERS>dINT) controls display brightness. You can select AUTO for automatic dimming of the display using the built-in light sensor, or manually select an intensity level from 10 to 100.

LAMP POWER

There are two settings that modify lamp control: Automatic Lamp On (PERS>ALON) and DMX Lamp-Off (PERS>DLOF).

There are three options for automatic lamp control: ON, OFF, and DMX. When ALON is OFF, the lamp remains off until a lamp-on command is received from the controller. When ALON is ON, the lamp strikes automatically after the fixture is powered on. When ALON is set to DMX, the lamp strikes automatically when the fixture receives DMX data, and it extinguishes automatically 15 minutes after DMX data is lost. When ALON is either ON or DMX, lamp strike timing is determined by the fixture address to prevent all lamps from striking at once.

The DMX Lamp-Off setting effects how the lamp can be turned off. When DLOF is ON, lamp power can be switched off by sending a DMX value from 248 to 255 on channel 1 for five seconds. When DLOF is OFF, the lamp-off command will not work unless special conditions are met. Refer to the DMX protocol.

RESET

The fixture can be reset from the controller if DMX reset (PERS>dRES) is ON. If DMX reset is OFF, this command will not work unless special conditions are met. Refer to the DMX protocol.

DEFAULT SETTINGS

The fixture can be reset to its factory default settings by selecting dFSE>FACT>LOAD.

Information readouts

POWER-ON HOURS

Read the total number of hours the fixture has been on since fabrication (`INFO>TIME>HRS>TOTL`), and the number of hours on since the counter was last reset (`INFO>TIME>HRS>RSET`). This can be used to track maintenance intervals. Press [up] for 5 seconds while displayed to reset.

LAMP HOURS

Read the total number of lamp hours since fabrication (`INFO>TIME>L HR>TOTL`), and the number of lamp hours since the counter was last reset (`INFO>TIME>L HR>RSET`). Reset this counter after installing a new lamp. Press [up] for 5 seconds while displayed to reset.

LAMP STRIKES

Read the total number of lamp strikes (`INFO>TIME>L ST>TOTL`), and the number of lamps strikes since the counter was last reset (`INFO>TIME>L ST>RSET`). Reset this counter when installing a new lamp. Press [up] for 5 seconds while displayed to reset.

FIRMWARE VERSION

`INFO>VER` displays the firmware version number. The firmware version is also displayed briefly at startup.

Test and service utilities

DMX READOUT

The DMX log (`dMXL`) menu provides useful information for troubleshooting control problems.

`RATE` displays the DMX refresh rate in packets per second. Values lower than 10 or higher than 44 may result in erratic performance, especially when using tracking control.

`QUAL` displays the quality of the received DMX data as a percentage of packets received. Values much below 100 indicate interference, poor connections, or other problems with the serial data link that are the most common cause of control problems.

`STCO` displays the DMX start code. Packets with a start code other than 0 may cause irregular performance.

The remaining options under `dMXL` display the DMX values received on each of the 13 channels, from `SHUT` (shutter, channel 1) to `EFS P` (effect speed, channel 13). If the fixture does not behave as expected, reading the DMX values can help you troubleshoot the problem.

MANUAL CONTROL

The manual control menu (`MAN`) provides commands for turning the lamp on (`LON`), turning the lamp off (`LOFF`), and resetting the fixture (`RST`). It also permits you to position and move individual effects.

EFFECTS TEST

The test sequence (`TSEQ>RUN`) runs through all effects to provide a quick check of fixture performance. Note: the test sequence does not automatically strike the lamp. Use `MAN>LON` and `MAN>LOFF` to control lamp power. Press [menu] to stop the test.

FEEDBACK TOGGLE

Magnetic sensors monitor the positions of the color wheel, gobo wheel, and rotating gobos. If they detect an error, the shutter closes while the effect resets. This feature can be disabled by turning effects feedback off (`UTIL>EFFb>OFF`).

ADJUSTMENT POSITIONS

The adjustment menu (`UTIL>AdJ`) provides commands for positioning effects during mechanical adjustment.

EFFECT CALIBRATION

With the calibration menu (`UTIL>CAL`), effect positions can be fine-tuned with a software-defined offset value to compensate for small misalignments or differences between fixtures.

The default offset command (`UTIL>dFOF`) erases any offsets stored in memory.

CIRCUIT BOARD TEST

`UTIL>PCBT` executes a routine designed for testing the main circuit board. For service use only.

UPLOAD MODE

The upload mode command (`UTIL>UPld`) prepares the fixture for a software update. This command is not necessary, however, as upload mode is engaged automatically by the uploader.

DMX-512 CONTROL

This section briefly describes the DMX-controllable effects. See also the DMX table starting on page 24 and the DMX chart on the back cover.

Lamp power

LAMP-ON

Unless automatic lamp strike is enabled, lamp power remains off until a lamp-on command is sent from the controller.

Note: A peak of electric current that can be many times the operating current is drawn for an instant when striking a discharge lamp. Striking many lamps at once may cause a voltage drop large enough to prevent lamps from striking or draw enough current to trip circuit breakers. If sending lamp-on commands to multiple fixtures, program a sequence that strikes lamps one at a time at 5 second intervals.

LAMP-OFF

The lamp can be turned off from the controller by sending the lamp-off command on channel 1 for 5 seconds. ***The lamp cannot be restruck for 8 minutes after being turned off.*** Note that the lamp-off command may be disabled by the DMX Lamp-Off personality setting.

Effect position

RESET

If an effect loses its indexing and fails to move to programmed positions, the fixture can be reset from the controller by sending the "Reset" command on channel 1 for 5 seconds. Note that the DMX reset feature may be disabled by the DMX Reset personality setting.

DIMMER / SHUTTER

The mechanical dimmer/shutter system provides full, high-resolution dimming, "instant" open and blackout, random and variable strobe effects, and random and variable pulses in which the dimmer snaps open and slowly dims or snaps closed and slowly opens. Shutter, strobe, and pulse effects are selected on channel 1. The intensity level is selected on channel 2.

COLOR

The color wheel can be scrolled continuously - allowing for split color effects - or in steps, and rotated randomly or continuously in both directions at different speeds.

GOBO ROTATION AND SELECTION

The MX-10 Extreme has 8 indexed-rotation gobo positions plus an open position. Gobos can be indexed (positioned at a defined angle), rotated continuously, or rotated and shaken (bounced). The gobo and the type of movement are selected on channel 4 and the index angle or rotation speed are selected on channel 5.

The gobo wheel also rotates continuously in both directions at variable speed.

FOCUS

The beam may be focused from approximately 2 meters (6.5 feet) to infinity.

ROTATING PRISM

The prism may be inserted and removed from the light path. It rotates in both directions at varying speeds.

PAN AND TILT

Mirror pan and tilt are controlled on channels 8 to 11. The course control channel sets first 8 bits (the most significant byte or MSB), and the fine channel sets the second 8 bits (the least significant byte or LSB) of the 16-bit control byte. In other words, the fine channel fine-tunes the position set by the course channel.

Speed control

TRACKING CONTROL

Tracking control is enabled by setting the speed channels (12 and 13) to one of the tracking values listed in the DMX table, typically 0.

With tracking control, the speed at which effects move is determined by the cross-fade time between two positions or scenes. The controller divides the move into steps and updates the fixture with small changes at the rate required to achieve the fade. The fixture “tracks” the changes and averages them with a digital filter algorithm to provide smooth movement.

VECTOR CONTROL

With vector control, movement speed is determined by the speed values on channels 12 and 13. This provides a way to control speed on controllers without cross-faders. Vector control also provides smoother movement, particularly at slow speeds, with controllers that send slow or irregular tracking updates.

When using vector control, the cross-fade time must be 0.

BLACKOUT

When “blackout while moving” is selected on channels 12 or 13, the shutter closes when the effect moves to make the transition invisible. The shutter opens when the movement is complete.

PERSONALITY OVERRIDES

Channel 12 provides tracking values that allow you to override the pan/tilt speed personality setting. Channel 13 provides tracking values that allow you to override the shortcuts setting. See the DMX table for details.

OPTICAL CONFIGURATION

Gobos

The MX-10 Extreme accepts eight metal or glass gobos with an outside diameter of 22.5 mm and a maximum image diameter of 17 mm. Complete gobo specifications are listed on page 35.

STANDARD GOBO CONFIGURATION

The MX-10 Extreme provides 8 gobos as shown below.

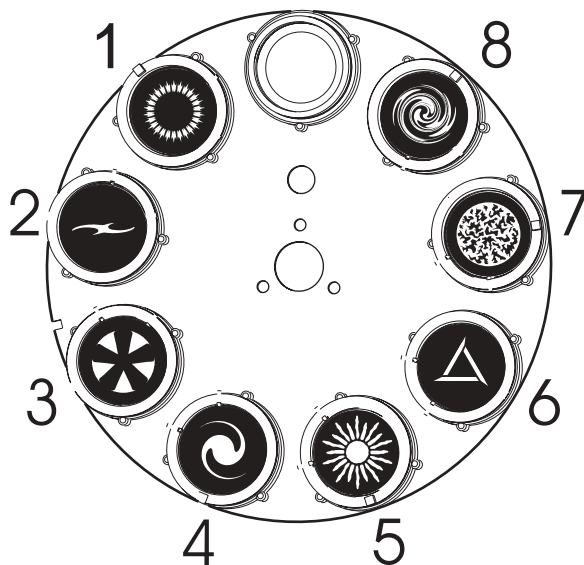

Figure 4: MX-10 Extreme gobo

Position	Gobo
1	Eclipse
2	Shark bar
3	Phat fan
4	Tail spin
5	Sun
6	Triangle
7	Oriental fire
8	Paint mix

Table 3: Standard gobos

CUSTOM GOBOS

For optimum performance, custom glass gobos for the MX-10 Extreme should be made with the text, logo, and similar artwork reversed on the coated side. Gobo types and dimensions are specified on page 34.

TO REPLACE A GOBO

- 1 Disconnect the fixture from AC power and allow it to cool.
- 2 Remove the front cover.
- 3 Turn the gobo wheel to access the desired position. Squeeze the ends of the retention spring together and remove. Push the gobo out from the back and remove.
- 4 Orient the gobo as shown in Figure 6 and insert. Secure the gobo with the retention spring.
- 5 Replace the cover before applying power.

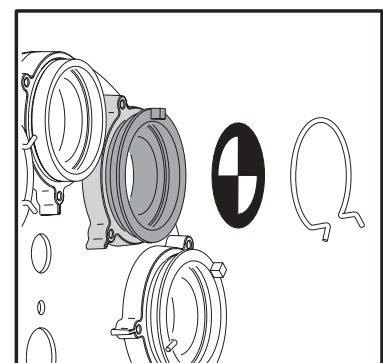

Figure 5: Gobo replacement

GOBO ORIENTATION

Figure 6 shows the correct orientation for different gobo types. When in doubt, install gobos with the more reflective side towards the lamp.

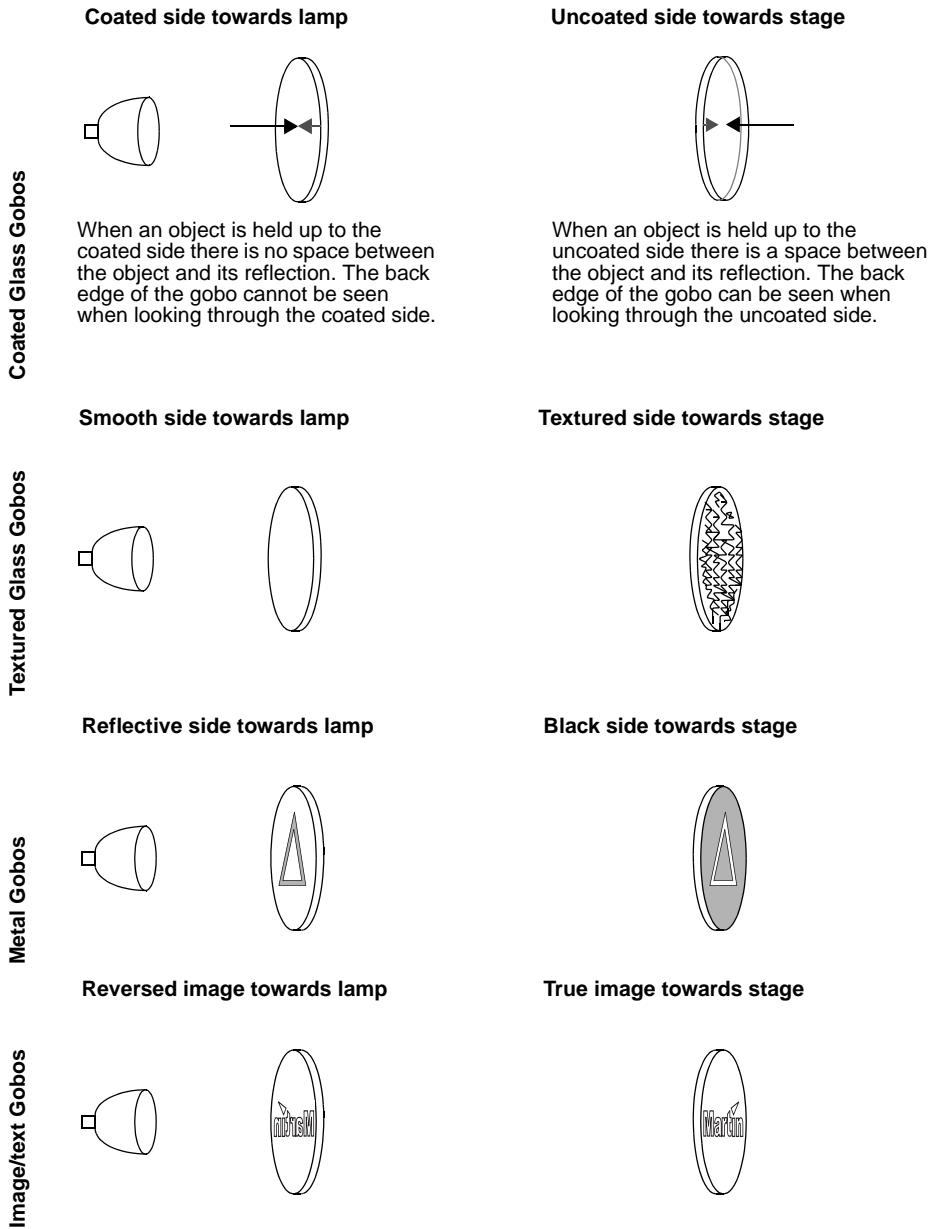

Figure 6: Gobo orientation

Color filters

STANDARD CONFIGURATION

The MX-10 Extreme provides 12 dichroic color filters as shown below.

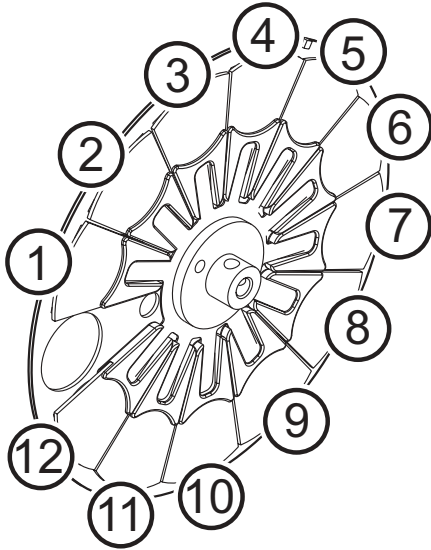

Figure 6: MX-10 Extreme color

Position	Color
1	CTC
2	Yellow 603
3	Blue 104
4	Pink 312
5	Green 206
6	Blue 108
7	Red 301
8	Magenta 507
9	Blue 101
10	Orange 306
11	Dark green
12	Purple 502

Table 4: Standard colors

TO REPLACE A COLOR FILTER

- 1 Disconnect the fixture from AC power and allow it to cool.
- 2 Remove the front cover.
- 3 Turn the color wheel to access the desired color filter. Press the filter forwards slightly to release it and then grasp it by the edges and remove.
- 4 To insert a filter, slide it under the retention spring until it snaps into place.
- 5 Replace the front cover.

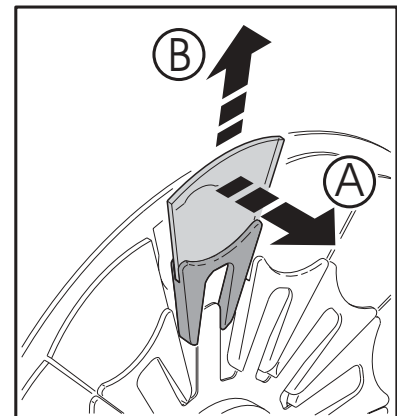

Figure 7: Filter replacement

Prism

The standard 3-facet prism can be replaced with optional five- and nine-facet prisms. See Accessories on page 35 for part numbers.

TO REPLACE THE PRISM

- 1 Disconnect the fixture from AC power and allow it to cool.
- 2 Remove the front cover.
- 3 Remove the three prism module screws. There are two screws on the color wheel side and one screw on the gobo wheel side.
- 4 Unfold the flexible wire retainers on each side of the chassis, just behind the prism module.
- 5 Unplug the color wheel sensor cable.
- 6 Lift the prism module out of the chassis. When the lower prism motor nears the color wheel sensor, tilt the prism module forward to avoid damaging the sensor connection pins.
- 7 Unplug the motors and remove the prism rotation belt.
- 8 Working through the round hole, lift the retention spring off the back of the prism holder.
- 9 Rock the prism gently from side to side while pulling lightly to work the prism out of the bearing. Do not use force. If the holder gets stuck, press it back into the bearing and try again.
- 10 Gently insert the replacement prism into the rotation bearing. Install the prism rotation belt.
- 11 Place the module prism-down on a clean surface with the prism centered in the round hole. Hold the unbent end of the retention spring in the prism holder groove with one hand and work the spring into the groove with your other hand.
- 12 Plug in the prism motors: the longer of the two cables is for the larger of the two motors.
- 13 Tilt the bottom motor away from the color wheel sensor as you insert the module into the fixture. When the motor is clear of the sensor connection pins, bring the module back to vertical and press it down into position so that the module tabs seat in the chassis slots.
- 14 Fold the flexible wire retainers over the cables on each side. Reconnect the color wheel sensor cable.
- 15 Fasten the prism module to the chassis with three screws.
- 16 Replace the front cover before applying power.

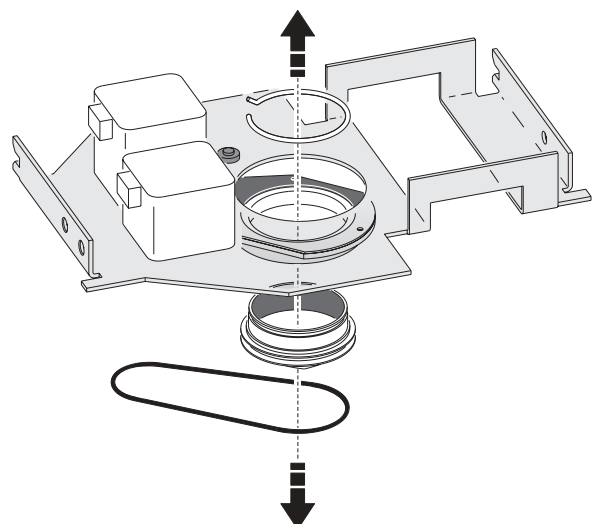
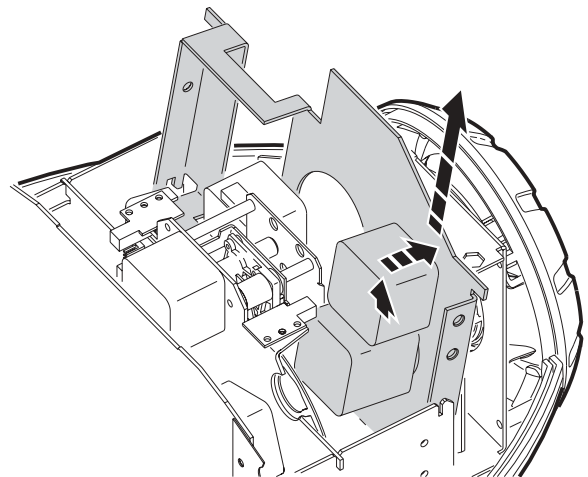
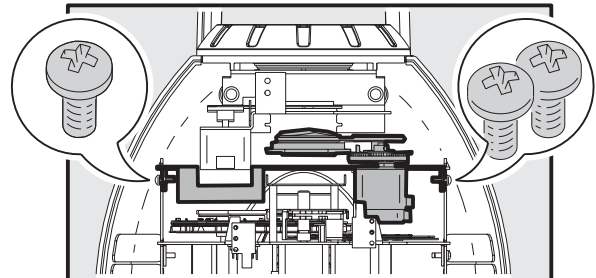

SERVICE

The MX-10 Extreme requires regular maintenance to keep performing at their peak. Excessive dust, grease, and smoke fluid buildup degrades performance and causes overheating and damage that is not covered by the warranty. The maintenance schedule will depend on the application and should be discussed with your Martin distributor. Refer any service that is not described here to a professional technician.

Warning! *Removing covers while the fixture is powered on exposes dangerous live electrical circuits, hot surfaces, and a lamp under high pressure. Disconnect the fixture from AC power and allow it to cool before removing any cover.*

Lamp replacement

Lamp life will vary; the rated life is an average figure that is based on the manufacturer's test cycle. For maximum lamp life, avoid excessive strikes and always allow the lamp to burn for at least 5 minutes before turning it off.

To reduce the risk of lamp explosion, which may damage the fixture, never exceed the lamp's rated life (2000 hours) by more than 25 percent.

Replace the lamp when:

- it strikes with difficulty or not at all, or is in any other way defective
- usage exceeds the manufacturer's "replace before" hours. See Table 1.

Refer to page 7 for the lamp replacement procedure.

Mirror replacement

No adjustment is required after replacing the mirror as long as you do not loosen the tilt motor shaft adaptor.

TO REPLACE THE MIRROR

- 1 Remove the two screws that fasten the mirror bracket to the tilt motor shaft adaptor with a 3 mm hex key and remove the mirror.
- 2 Apply a drop of threadlock such as Loctite 243 to each screw.
- 3 Place the new mirror assembly on the shaft adaptor and fasten securely.

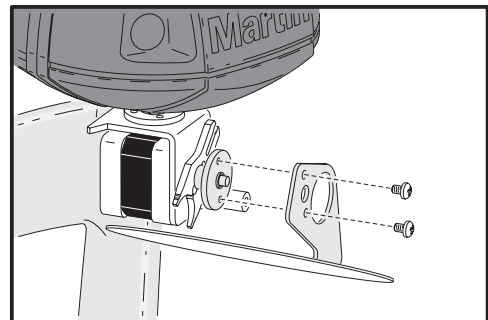

Cleaning

OPTICAL COMPONENTS

Use care when cleaning optical components. The surface on dichroic filters is achieved by means of special multi-layer coatings and even small scratches may be visible. Residues from cleaning fluids can bake onto components and ruin them.

- 1 Allow the components to cool completely.
- 2 Wash dirty lenses and filters with isopropyl alcohol. A generous amount of regular glass cleaner may also be used, but no residues may remain.
- 3 Rinse with distilled water. Mixing the water with a small amount of wetting agent such as Kodak Photoflo will help prevent streaking and spotting.

- 4 Dry with a clean, soft and lint-free cloth or blow dry with compressed air.

FAN

To maintain adequate cooling it is important that the fan be cleaned regularly.

- 1 Remove the fan by pulling out the locking pins on each side.
- 2 Clean with a soft brush, vacuum, or compressed air.
- 3 Place the fan back in position and press in the locking pins to secure.

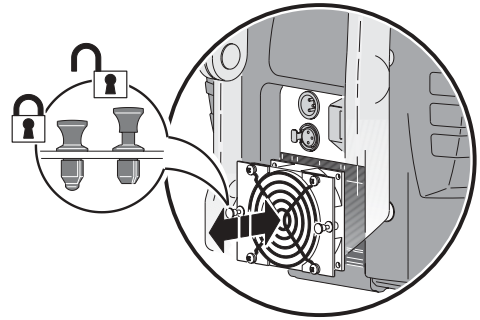

Lubrication

Use only silicone lubricant, Martin P/N 37302003 (500 ml) or P/N 37302004 (200 ml, in applicator bottle). No other lubricant is approved for use. When applying lubricant, always remove excess and do not get oil on other parts.

- 1 Check the focus mechanism and apply a drop of lubricant to the 3 metal slides if movement is rough.
- 2 Lubricate the rotating-gobo bearings if movement is rough on slow rotation or if they become noisy. Apply a few drops of oil to each bearing from the lamp side of the wheel.

Replacing fuses

MAIN FUSE

The main fuse holder is built in to the mains input socket. *Never replace the fuse with one of a different rating!*

- 1 Unplug the mains cable from the input socket.
- 2 Pry open the fuse holder and remove the fuse.
- 3 Replace the fuse with one of the same type and rating. The fuse rating is listed on serial number label.
- 4 Close the fuse holder and replace the mains cable.

AC input & fuse holder

Data input

Data output

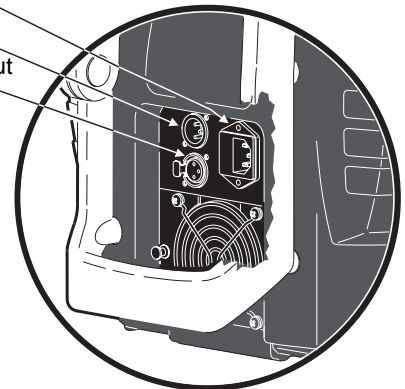

POWER SUPPLY FUSES

There are two fuses for the low-voltage power supplies located on the printed circuit board. If one or more of the green LEDs on the PCB does not light, one of these fuses may be blown. If all three LEDs are lit, the low-voltage power supplies are functioning correctly.

Have the fixture serviced by a Martin service technician if the problem persists.

- 1 Disconnect the fixture from AC power.
- 2 Remove the front cover.
- 3 Remove the four screws that fasten the control panel assembly. Move the display assembly out of the way to access the PCB.
- 4 Carefully remove and check the two fuses located in the top-left corner of the PCB (see page 33). Replace as necessary with fuses of the same size and rating (see page 34).
- 5 Install the control panel and the front cover.

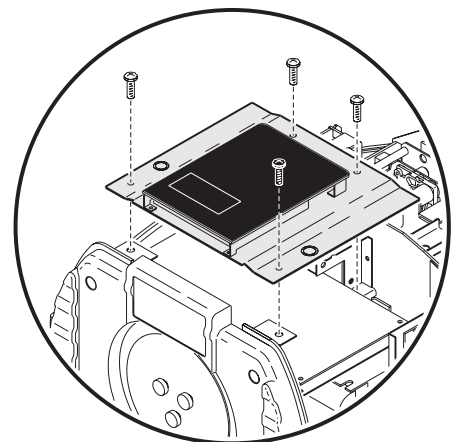

Updating software

The latest MX-10 Extreme firmware is available from the support area of the Martin web site at www.martin.dk. It can be installed via the serial data link using a supported Martin uploader such as the MP-2, or via a LightJockey 4064 ISA DMX interface.

Note: Intermediate control systems such as the Martin Lighting Director (MLD) and the Martin Matrix must be bypassed when updating fixture software via the DMX link. These systems do not relay the update code correctly because it is not a DMX-compliant signal.

NORMAL UPDATE

To update fixture software, connect an upload device to the fixture just as you would connect a DMX controller and perform a DMX mode upload as described in the uploader's documentation. There is no need to isolate the MX-10 Extreme fixtures from other types of fixture on the serial link.

When the upload is completed (and when booting up) the MX-10 Extreme performs a check-sum test of the flash memory and then resets. If the firmware is corrupted a check-sum error (C S E R) occurs. A few seconds later the fixture displays U P L d and is ready for a new DMX-mode upload.

In the unlikely event that a software upload is interrupted, the fixture must be powered off for at least 10 seconds to force the check-sum test. You can repeat the DMX-mode upload as soon as U P L d is displayed.

BOOT SECTOR UPDATE

If the normal update procedure fails or the software update notes call for a boot-sector update, install new software as follows.

- 1 Disconnect the fixture from AC power.
- 2 Remove the front cover.
- 3 Remove the four screws that fasten the display assembly. Move the display assembly out of the way to access the PCB.
- 4 The boot sector jumper is located next to the plug for the control panel data cable. Move the jumper to the Init setting. Verify that the Flash Write jumper is in the Enable position. See the diagram on page 33.
- 5 Perform a boot-mode upload as described in the uploader manual.
- 6 Disconnect the fixture from AC power. Move the jumper back to the Lock setting.
- 7 Install the control panel and the front cover.

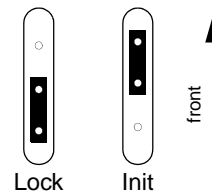
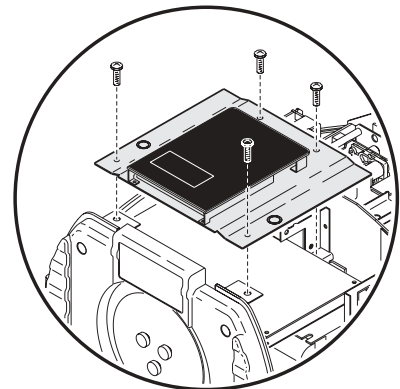

DMX PROTOCOL



Channel	Value	Percent	Function
			Shutter, Strobe, Reset, Lamp On/Off
	0 - 19	0 - 7	Shutter closed
	20 - 49	8 - 19	Shutter open
	50 - 72	20 - 28	Strobe, fast→slow
	73 - 79	29 - 31	Shutter open
	80 - 99	31 - 39	Opening pulse, fast →slow
	100 - 119	39 - 47	Closing pulse, fast →slow
	120 - 127	47 - 50	Shutter open
	128 - 147	50 - 58	Random strobe, fast
1	148 - 167	58 - 65	Random strobe, medium
	168 - 187	66 - 73	Random strobe, slow
	188 - 190	74 - 75	Shutter open
	191 - 193	75 - 76	Random opening pulse, fast
	194 - 196	76 - 77	Random opening pulse, slow
	197 - 199	77 - 78	Random closing pulse, fast
	200 - 202	78 - 79	Random closing pulse, slow
	203 - 207	80 - 81	Shutter open
	208 - 217	82 - 85	Reset fixture: time > 5 seconds, see note 1
	218 - 227	85 - 89	Shutter open
	228 - 237	89 - 93	Lamp on
	238 - 247	93 - 97	Shutter open
	248 - 255	97 - 100	Lamp off: time > 5 seconds, see note 1
			Dimmer
2	0 - 255	0 - 100	Closed → open

¹If this command is disabled in the menu, it can be executed only if the CTC filter, prism with no rotation, and open gobo are selected.

Channel	Value	Percent	Function
			Color
			Continuous Scroll: full color positions:
	0	0	White
	12	5	CTC
	24	9	Yellow 603
	36	14	Blue 104
	48	19	Pink 312
	60	23	Green 206
	72	28	Blue 108
	84	33	Red 301
	96	37	Magenta 507
	108	42	Blue 101
	120	47	Orange 306
	132	42	Dark green
	144	56	Purple 502
			Stepped Scroll
	156 - 159	61 - 63	Purple 502
	160 - 163	63 - 64	Dark green
3	164 - 167	64 - 65	Orange 306
	168 - 171	66 - 67	Blue 101
	172 - 175	67 - 68	Magenta 507
	176 - 179	69 - 70	Red 301
	180 - 183	70 - 72	Blue 108
	184 - 187	72 - 73	Green 206
	188 - 191	74 - 75	Pink 312
	192 - 195	75 - 76	Blue 104
	196 - 199	77 - 78	Yellow 603
	200 - 203	78 - 79	CTC
	204 - 207	80 - 81	White
			Continuous Rotation
	208 - 226	82 - 88	CW, fast → slow
	227 - 245	89 - 96	CCW, slow → fast
			Random color
	246 - 248	96 - 97	Fast
	249 - 251	98 - 98	Medium
	252 - 255	99 - 100	Slow

Channel	Value	Percent	Function
			Gobo selection and shake
	0 - 4	0 - 1	Indexing: set position on channel 5
	5 - 9	1 - 3	Open gobo
	10 - 14	3 - 5	Gobo 1
	15 - 19	6 - 7	Gobo 2
	20 - 24	7 - 9	Gobo 3
	25 - 29	9 - 11	Gobo 4
	30 - 34	11 - 13	Gobo 5
	35 - 39	13 - 15	Gobo 6
	40 - 44	15 - 17	Gobo 7
			Gobo 8
	45 - 49	17 - 19	Rotation: set velocity on channel 5
	50 - 54	19 - 21	Open gobo
	55 - 59	21 - 23	Gobo 1
	60 - 64	23 - 25	Gobo 2
	65 - 69	25 - 27	Gobo 3
4	70 - 74	27 - 29	Gobo 4
	75 - 79	29 - 31	Gobo 5
	80 - 84	31 - 33	Gobo 6
	85 - 89	33 - 35	Gobo 7
			Gobo 8
	90 - 104	35 - 40	Rotation with shake, slow → fast: set velocity on ch. 5
	105 - 119	41 - 46	Gobo 8
	120 - 134	47 - 52	Gobo 7
	135 - 149	53 - 58	Gobo 6
	150 - 164	59 - 64	Gobo 5
	165 - 179	65 - 70	Gobo 4
	180 - 194	70 - 76	Gobo 3
	195 - 209	76 - 82	Gobo 2
			Gobo 1
	210 - 232	82 - 91	Continuous scroll: set velocity of gobo rotation on ch. 5
	233 - 255	91 - 100	CW slow → fast CCW fast → slow
			Gobo rotation (select gobo on channel 4)
	0 - 255	0 - 100	Index position 0 - 395°
5			Continuous rotation (direction and speed)
	0 - 2	0 - 1	No rotation
	3 - 127	1 - 50	CW, slow → fast
	128 - 252	50 - 98	CCW, fast → slow
	253 - 255	99 - 100	No rotation
			Focus
6	0 - 255	0 - 100	Infinity → 2 meters
			Prism
	0 - 19	0 - 7	Prism off
	20 - 79	8 - 31	Rotating prism, CCW fast → slow
	80 - 89	31 - 35	No rotation
	90 - 149	35 - 58	Rotating prism, CW slow → fast
	150 - 215	59 - 84	Prism off
7			Prism/Gobo Macros
	216 - 220	84 - 86	Macro 1
	221 - 225	87 - 88	Macro 2
	226 - 230	89 - 90	Macro 3
	231 - 235	91 - 92	Macro 4
	236 - 240	93 - 94	Macro 5
	241 - 245	95 - 96	Macro 6
	246 - 250	96 - 98	Macro 7
	251 - 255	98 - 100	Macro 8
			Pan
8	0 - 255	0 - 100	Left → right (128 = neutral)
			Pan Fine (LSB)
9	0 - 255	0 - 100	Left → right

Channel	Value	Percent	Function
10	0 - 255	0 - 100	Tilt Up → down (128 = neutral)
11	0 - 255	0 - 100	Tilt Fine (LSB) Up → down
12	0 - 2 3 - 245 246 - 248 249 - 251 252 - 255	0 - 1 1 - 96 96 - 97 98 - 98 99 - 100	Pan/Tilt Speed Tracking Fast → slow Tracking, PTSP NORM (menu override) Tracking, PTSP FAST (menu override) Blackout while moving
13	0 - 2 3 - 245 246 - 251 252 - 255	0 - 1 1 - 96 96 - 98 99 - 100	Effects Speed Dimmer, focus Tracking mode Fast → slow Tracking Maximum speed
	0 - 2 3 - 245 246 - 248 249 - 251 252 - 255	0 - 1 1 - 96 96 - 97 98 - 98 99 - 100	Color Tracking mode Speed, fast → slow Tracking, SCUT OFF (menu override) Tracking, SCUT ON (menu override) Blackout while moving
	0 - 245 246 - 248 249 - 251 252 - 255	0 - 96 96 - 97 98 - 98 99 - 100	Gobo selection Normal (no blackout) Normal, SCUT OFF (menu override) Normal, SCUT ON (menu override) Blackout while moving
	0 - 2 3 - 245 246 - 251 252 - 255	0 - 1 1 - 96 96 - 98 99 - 100	Indexed gobo rotation Tracking mode Fast → slow Tracking Blackout while moving
	0 - 251 252 - 255	0 - 98 99 - 100	Prism Normal (no blackout) Blackout while moving

CONTROL MENU



Menu	Item	Options	Notes (Default settings in bold print)
Addr	-	1 - 512	DMX address
PATI	SWAP	ON	Map DMX pan control to tilt channel and vice versa.
		OFF	Normal pan and tilt control
	PINV	ON	Reverse DMX pan control, right → left
		OFF	Normal pan control, left → right
	TINV	ON	Reverse DMX tilt control, down → up
		OFF	Normal tilt control, up → down
PTSP	-	NORM	Default pan/tilt speed
		FAST	Maximum pan/tilt speed (position may be less precise)
PERS	dISP	ON	Display remains on
		OFF	Display extinguishes 2 minutes after last key press
	dINT	AUTO	Automatic display dimming
		10 - 100	Set display intensity manually
	dLOF	ON	Enable DMX lamp off command
		OFF	Disable DMX lamp off command
	dRES	ON	Enable DMX reset command
		OFF	Disable DMX reset command
	ALON	ON	Lamp strikes automatically within 90 seconds of power on
		OFF	No automatic lamp strike
		dMX	Lamp strikes if DMX is present, douses 15 mins. after it's missing
	SCUT	ON	Effect wheels turn shortest distance
		OFF	Effect wheels do not cross open position
	dFSE	FACT	LOAD
INFO	TIME / HRS	TOTL	Total hours of operation since fabricated
		RSET	Hours of operation since counter reset. To reset, display counter and press [up] for 5 seconds.
	TIME / L HR	TOTL	Total hours of operation with lamp on since fabricated
		RSET	Lamp hours since counter reset. To reset, display counter and press [up] for 5 seconds.
	TIME / L ST	TOTL	Total number of lamp strikes since fabricated
		RSET	Number of lamp strikes since counter reset. To reset, display counter and press [up] for 5 seconds.
VER	-	-	CPU firmware version
dMXL	-	RATE	DMX packets per second
		QUAL	Percentage of data received without errors
		STCO	Decimal value of the DMX start code.
		SHUT . . EFSP	DMX value (from 0 - 255) received for each channel.

Table 5: Control menu

Menu	Item	Options	Notes (Default settings in bold print)	
MAN	RST	-	Reset fixture	
	L ON	-	Lamp on	
	L OFF	-	Lamp off	
	SHUT	OPEN		Open shutter
		CLOS		Close shutter
		STRF		Fast strobe
		STRM		Medium strobe
		STRS		Slow strobe
	dIM	0 - 255	Dimmer	
	COL	OPEN		Color wheel in open position.
		C1 - C12		Color wheel positions 1 > 12.
		CW F		Clockwise rotation - fast
		CCWF		Counter-clockwise rotation - fast
		CW M		Clockwise rotation - medium
		CCWM		Counter-clockwise rotation - medium
		CW S		Clockwise rotation - slow
		CCWS		Counter-clockwise rotation - slow
		RNdF		Random color - fast
		RNdM		Random color - medium
		RNdS		Random color - slow
	gObO	OPEN		Gobo wheel in open position
		g1 I - g7 I		Indexed gobos 1-7
		g1 R - g7 R		Rotating gobos 1-7
		g1RS - g7RS		Rotating gobo shake 1-7
		CW F		Clockwise rotation, fast
		CCWF		Counter-clockwise rotation, fast
		CW M		Clockwise rotation, medium
		CCWM		Counter-clockwise rotation, medium
		CW S		Clockwise rotation, slow
		CCWS		Counter-clockwise rotation - slow
	I / S	0 - 255	Clockwise rotation of gobo wheel. Slow - fast.	
	PRIS	ON		Prism in
		OFF		Prism out
RPRI	0 - 255	Rotate prism, slow - fast		
FOC	0 - 255	Focus, Infinity→Near		
PAN	0 - 255	Pan, Left→Right		
TILT	0 - 255	Tilt, Up→Down		
TSEQ	-	RUN	Run a general test of all effects	

Table 5: Control menu

Menu	Item	Options	Notes (Default settings in bold print)
UTIL (Press and hold Enter for a few seconds)	EFF b	ON	Enable on the fly reset of magnetically indexed effects
		OFF	Disable on the fly reset of magnetically indexed effects
	Ad j	-	Not implemented
	CAL	-	Not implemented
	dFOF	SURE	Return all offsets to the default settings
	PCbT	LEd	PCB test for service use only.
	UPLd	SURE	Manually set fixture to software update mode

Table 5: Control menu

ERROR MESSAGES



Display readout	Appears if...	What to do
MERR (Memory error)	...the EEPROM memory cannot be read.	<ul style="list-style-type: none">• Contact service technician.
CSER (Check-sum error)	...a software upload is unsuccessful.	<ul style="list-style-type: none">• Reload software, see page 23.
****	... there is no communication between the control panel and motherboard. This appears briefly when switching on the fixture.	<ul style="list-style-type: none">• Check fuses.• Check cable between control panel and motherboard.• Reinstall software.• Contact service technician.
COER (Color wheel time-out) rgER (Rot. gobo time-out) goER (Gobo index time out)	...the magnetic-indexing circuit malfunctions (e.g. sensor defective or magnet missing).	<ul style="list-style-type: none">• After the time-out, the effect in question stops in a random position.• Contact service technician.

Table 6: Error messages

TROUBLESHOOTING

D

Problem	Probable cause(s)	Remedy
One or more of the fixtures is completely dead.	No power to fixture.	<ul style="list-style-type: none"> Check that power is switched on and cables are plugged in.
	Primary fuse blown.	<ul style="list-style-type: none"> Replace fuse.
	Secondary fuse(s) blown (located on PCB inside base).	<ul style="list-style-type: none"> Check fuses on PCB and replace.
Fixtures reset correctly but all respond erratically or not at all to the controller.	The controller is not connected.	<ul style="list-style-type: none"> Connect controller.
	XLR pin-out of the controller does not match pin-out of the first fixture on the link (i.e. signal is reversed).	<ul style="list-style-type: none"> Install a phase-reversing cable between the controller and the first fixture on the link.
Fixtures reset correctly but some respond erratically or not at all to the controller.	Poor data quality	<ul style="list-style-type: none"> Check data quality (page 13). If much under 100 percent, the problem may be a bad data link connection, poor quality or broken cabling, missing termination, or a defective fixture disturbing the link.
	Bad data link connection	<ul style="list-style-type: none"> Inspect connections and cables. Correct poor connections. Repair or replace damaged cables.
	Data link not terminated with 120Ω termination plug.	<ul style="list-style-type: none"> Insert termination plug in output jack of the last fixture on the link.
	Incorrect addressing of the fixtures.	<ul style="list-style-type: none"> Check address setting.
	One of the fixtures is defective and disturbs data transmission on the link.	<ul style="list-style-type: none"> Bypass one fixture at a time until normal operation is regained: unplug both connectors and connect them directly together. Have the defective fixture serviced by a qualified technician.
	XLR pin-out on fixtures does not match (pins 2 and 3 reversed).	<ul style="list-style-type: none"> Install a phase-reversing cable between the fixtures or swap pins 2 and 3 in the fixture that behaves erratically.
Shutter closes suddenly.	The color wheel, gobo wheel, or a gobo has lost its index position and the fixture is resetting the effect.	<ul style="list-style-type: none"> Contact Martin technician for service if the problem persists.
No light and "LERR" error message displayed.	The power supply settings do not match local AC voltage and frequency.	<ul style="list-style-type: none"> Disconnect fixture. Check settings (page 8) and correct if necessary.
	Lamp missing or blown	<ul style="list-style-type: none"> Disconnect fixture and replace lamp.
Lamp cuts out intermittently.	Fixture is too hot.	<ul style="list-style-type: none"> Allow fixture to cool. Clean fan. Make sure air vents at control panel and front lens are not blocked. Turn up the air conditioning.
	The power supply settings do not match local AC voltage and frequency.	<ul style="list-style-type: none"> Disconnect fixture. Check settings (page 8) and correct if necessary.

Table 7: Troubleshooting

PCB CONNECTIONS

E

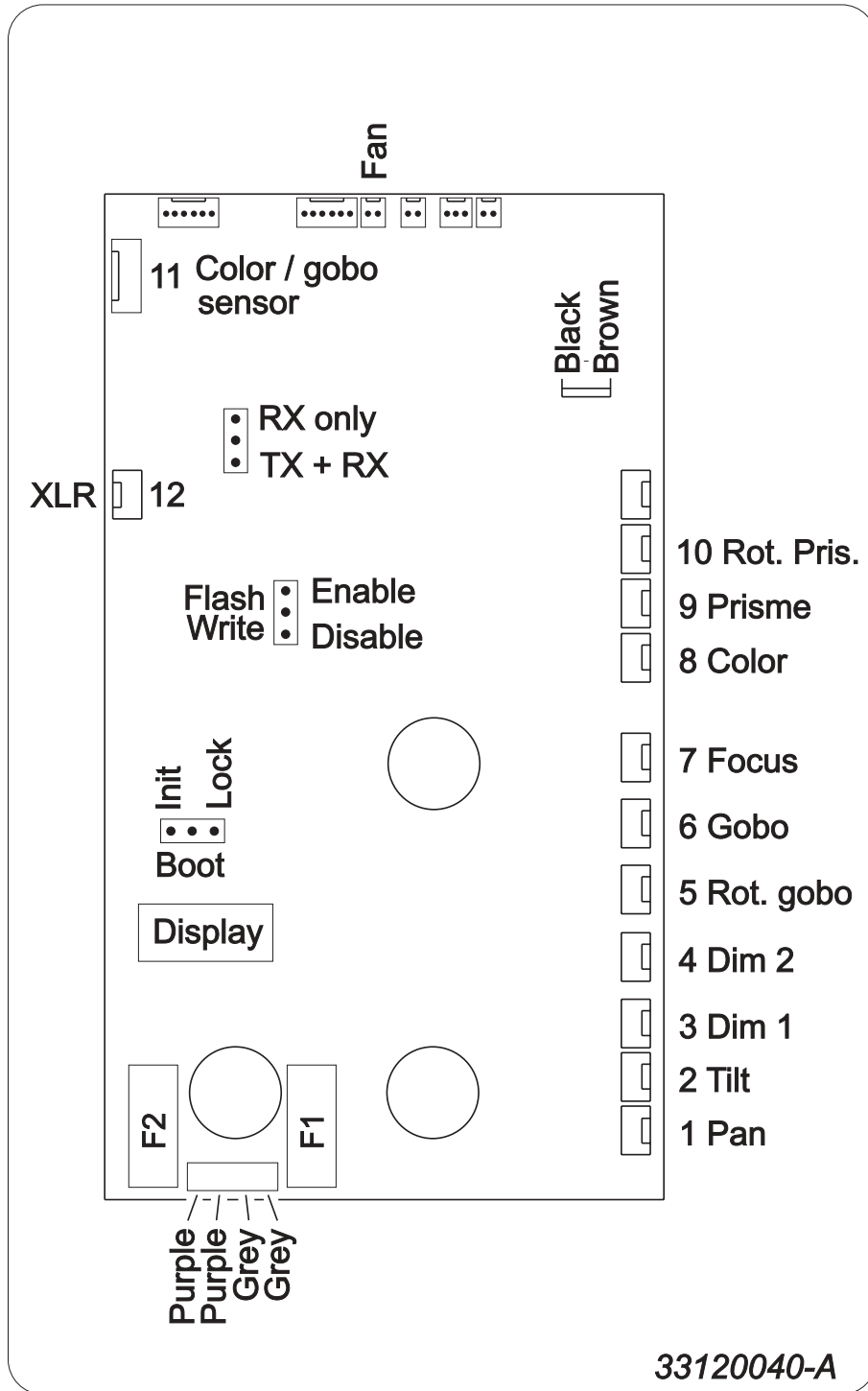

33120040-A

SPECIFICATIONS - MX-10 EXTREME

PHYSICAL

Length	735 mm (29.0 in)
Width	340 mm (13.4 in)
Height	315 mm (12.4 in)
Weight	22 kg (48.4 lbs)

AC POWER

Operating range	100 - 250 V, 50/60 Hz
AC input	3-prong IEC male socket

MAXIMUM POWER AND CURRENT

100 V, 50 Hz	350 W, 4.2 A
120 V, 50 Hz	340 W, 3.2 A
208 V, 50 Hz	350 W, 2.1 A
230 V, 50 Hz	360 W, 1.8 A
250 V, 50 Hz	350 W, 1.6 A
100 V, 60 Hz	340 W, 4.1 A
120 V, 60 Hz	340 W, 2.9 A
208 V, 60 Hz	340 W, 1.8 A
230 V, 60 Hz	350 W, 1.6 A
250 V, 60 Hz	350 W, 1.5 A

THERMAL

Maximum ambient temperature (T _a)	40° C (104° F)
Maximum surface temperature	50° C (122° F)

INSTALLATION

Orientation	any
Minimum distance to flammable materials	0.1 m (4 in)
Minimum distance to illuminated surfaces	0.3 m (12 in)

FUSES

Main fuse	6.3 A / 250 V, time-delay
Fuse F1	6.3 A / 250 V, time-delay
Fuse F2	2.0 A / 250 V, time-delay

LAMPS

Osram HSD 250	2000 hr, 6000K, 250 W, 68 lm/W
Philips MSD 250/2	2000 hr, 6500K, 250 W, 72 lm/W
Philips MSD 200	2000 hr, 5600K, 200 W, 67 lm/W

PHOTOMETRICS

Beam angle	18°
Pan/tilt range	230° / 75°
Light output (w/ Philips MSD250/2)	3,757 lumens
Maximum illuminance	120,000 Cd

GOBOS

Outside diameter	22.5 mm + 0/- 0.3 mm (0.886 in. +0/- 0.012 in)
Maximum image diameter	17 mm (0.669 in)
Maximum thickness	1.8 mm (0.071 in)
Glass type	high temperature Borofloat or better
Glass coating	dichroic or enhanced aluminum
Metal	aluminum (steel okay for short use)

CONTROL AND PROGRAMMING

Data input	locking 3-pin XLR male socket
Data output	locking 3-pin XLR female socket
Data pinout	pin 1 shield, pin 2 cold (-), pin 3 hot (+)
Receiver	Opto-isolated RS-485
Protocols	USITT DMX-512 (1990)
DMX Channels	13

DESIGN STANDARDS

Canadian safety	CSA C22.2 NO 166
EU EMC	EN 50 081-1, EN 50 082-1
EU safety	EN 60598-1, EN 60598-2-17
US safety	ANSI/UL 1573

ORDERING INFORMATION

MX-10 Extreme	P/N 90145400
---------------------	--------------

ACCESSORIES

5-facet prism in holder	P/N 91611062
9-facet prism in holder	P/N 91611063
Replacement mirror assembly	P/N 62333029
G-clamp	P/N 91602003
Half-coupler clamp	P/N 91602005

Start code = 0
Implemented from CPU 1.2

MX-10 Extreme DMX

CHANNEL		25 50 75 100 125 150 175 200 225 250																															
L I G H T	1	SHUTTER					STROBE					DIMMER PULSE					RANDOM STROBE					RND PULSE		RESET		OPEN		LAMP ON		LAMP OFF*			
	2	closed	open				←				opening	closing				fast	med	slow		open	close	*	208	217	218	227	228	237	238	247	> 5 sec. 248 255		
C L O U R	3	CONTINUOUS COLOR SCROLL												STEPPED COLOR SCROLL								CONTINUOUS ROTATION				RND COLOR							
	0	white	C 1	C 2	C 3	C 4	C 5	C 6	C 7	C 8	C 9	C 10	C 11	C 12	12	11	10	9	8	7	6	5	4	3	2	*	0	208	←	226	227	→	245
G O B O S	4	INDEXED GOBO SELECTION				ROTATING GOBO SELECTION				GOBO SHAKE								CONTINUOUS ROTATION															
	0*	0	1	2	3	4	5	6	7	8	0*	1	2	3	4	5	6	7	8	G 8	G 7	G 6	G 5	G 4	G 3	G 2	G 1	210	→	232	233	←	255
F O C U S	5	GOBO ROTATION																															
	0°	continuous cw rotation →												indexing								← continuous ccw rotation				395°							
P A N / T I L T	6	infinity																															
	7	2 meters																															
S P E E D	8	left																															
	9	right																															
S P E E D	10	left																															
	11	right																															
S P E E D	12	up																															
	13	down																															
S P E E D	12	up																															
	13	down																															
S P E E D	12	T 3 fast																															
	13	slow 245 T _s T _f «»																															
S P E E D	12	T 3 dimmer, focus																															
	13	←																															
S P E E D	12	T 3 colors																															
	13	←																															
S P E E D	12	T 3 gobo indexing																															
	13	←																															
S P E E D	12	0 gobo selection																															
	13	no change																															
S P E E D	12	0 rotating prism																															
	13	no change																															
		EFFECTS SPEED												* Set ch. 3, 4, and 7 to value marked to override disabled function.																			
		←												T = tracking mode (0-2 & 246-251)																			
		←												S = normal PTSP / shortcuts off (Overrides personality setting)																			
		←												F = fast PTSP / shortcuts on (Overrides personality setting)																			
		no change												«» = blackout speed (252-255)																			
		no change												← = variable speed, points to fast																			
		no change												245 T f																			
		no change												245 T _s T _f «»																			
		no change												245 T «»																			
		no change												245 S F «»																			
		no change												251 «»																			