

SHOWPRO

Neptune Super Beam MANUAL

LEDMOV655

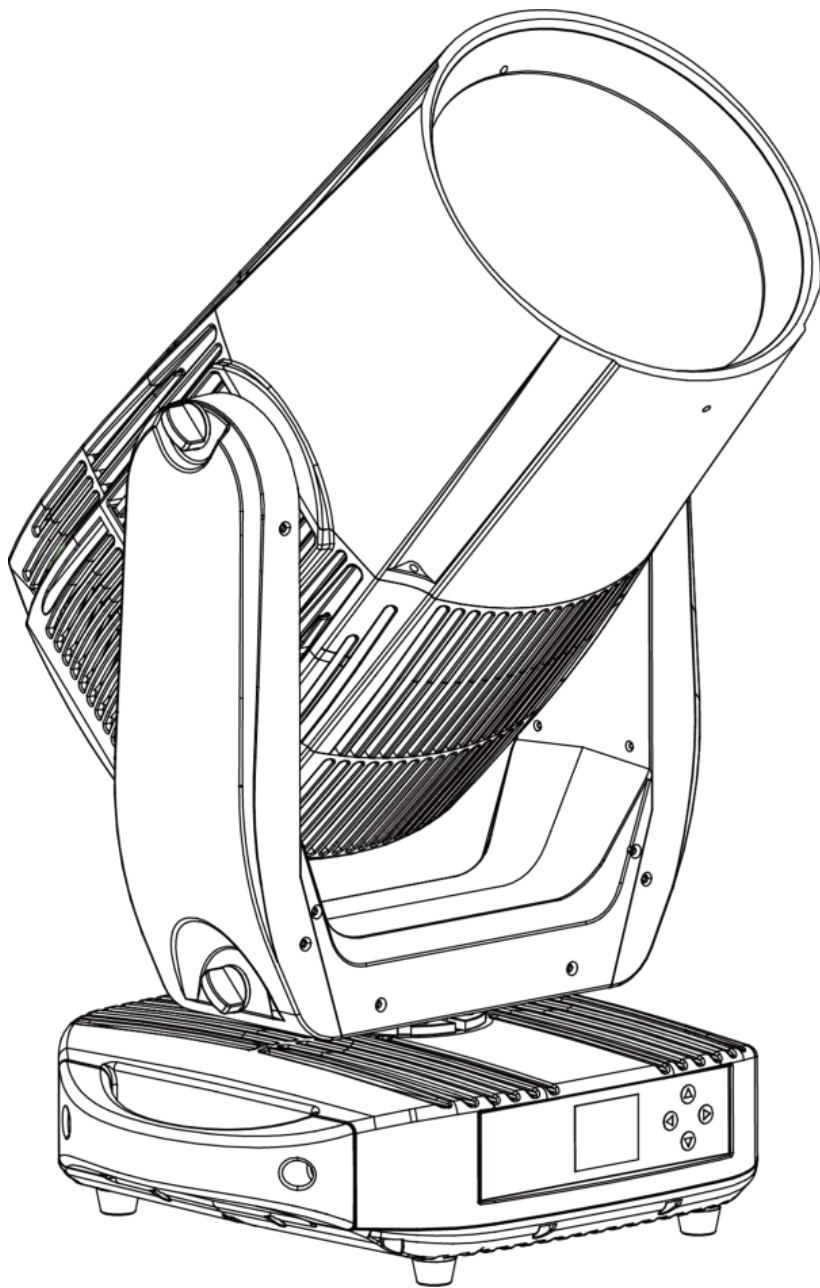

1 PRODUCT

1.1 TECHNICAL SPECIFICATIONS

LED coloUrs	260W Laser source
Angle	1°
Power	400W
Control Protocol	DMX512, RDM, ARTNET, sACN, W-DMX (Optional)
Voltage Range	AC100~240V,50/60Hz
Input Current	110V/3.2A,220V/1.6A
Protection	IP65
Operation Temperature	-20°C~45°C
Dimensions	416x358x712mm
Weight	39kg

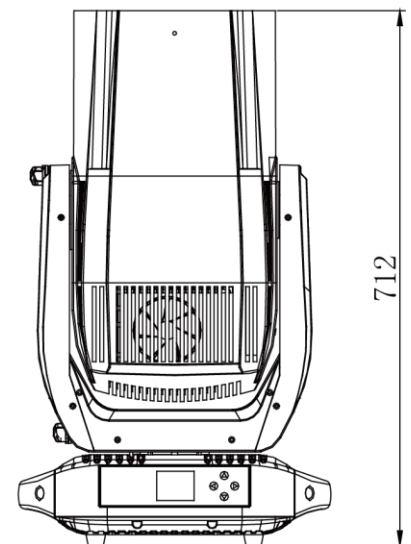
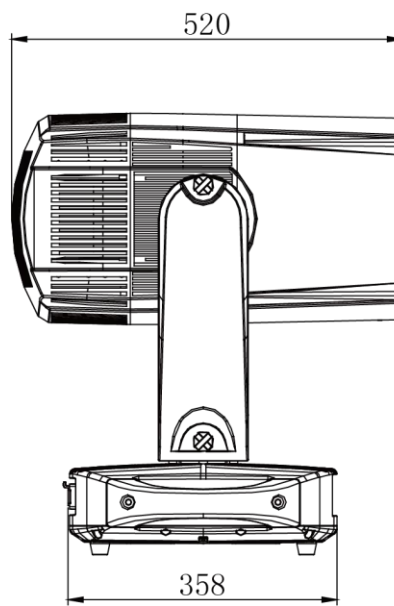
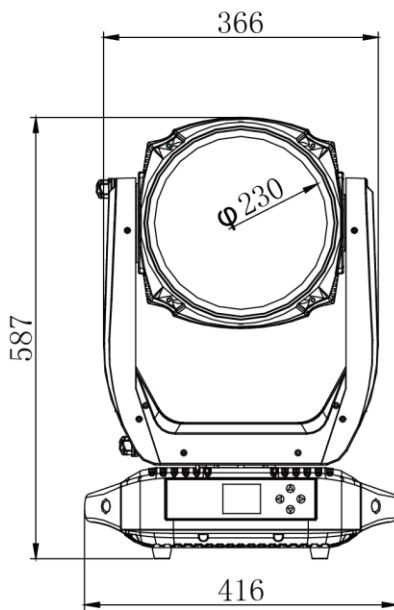
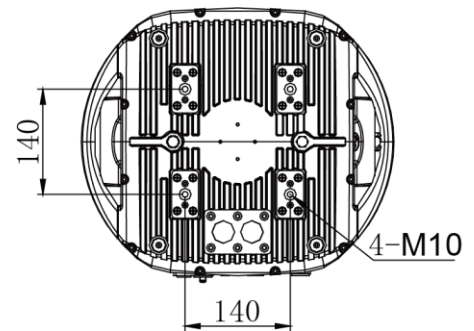

1.2 Safety Notes

IMPORTANT

- This product must be installed by a qualified professional.
- In order to maintain this condition and to ensure a safe operation, it is absolutely necessary for the user to follow the safety instructions and warning notes
- The manufacturer will not accept liability for any resulting damages caused by the non-observance of this manual or any unauthorized modification to the device.

CAUTION!

- Make sure that the available voltage is not higher than stated on the rear panel.
- Do not touch the power cables if your hands are wet.
- The earth wire must always be connected to the ground. Therefore it is essential to connect the yellow/green conductor to earth.
- Make sure that the power-cord is never crimped or damaged by sharp edges. Check the device and the power-cord from time to time. The electric connection, repairs and servicing must be carried out by a qualified employee.
- Always disconnect power input cable to completely remove power from unit when not in use or before cleaning or servicing the fixture.
- Do not switch the fixture on and off in short intervals as this would reduce the lamp's life.
- Do not touch the device's housing bare hands during its operation (housing becomes hot)! The surface of the product's casing can reach up to 60° C (140° F) during operation. Avoid contact by persons and materials. Do not install the product in a location where there is a risk of accidental contact. Allow the product to cool for at least 10 minutes before handling.
- For replacement use lamps and fuses of same type and rating only.
- Please protect the fixture and avoid destroy during transport and installation. If there is any damage to the coating, the shell may be corroded.
- When hanging lamps and lanterns, it is necessary to verify that facilities and hooks can bear at least 10 times the weight of lamps and lanterns.
- Fix the safety rope at the correct holes only. Only operate the fixture after having checked that the housing is firmly closed and all screws are tightly fastened.
- The maximum ambient temperature 45°C must never be exceeded. Do not operate the product if the ambient temperature (Ta) exceeds 45° C (115° F).
- During the initial start-up some smoke or smell may arise. This is a normal process and does not necessarily mean that the device is defective.

Electrical Warning

- The light source contained in this luminaire shall only be replaced by the manufacturer or his service agent or a similar qualified person
- For replacement use lamps and fuses of same type and rating only.
- The lens has to be replaced when it is obviously damaged, so that its function is impaired, e. g. due to cracks or deep scratches!

Keep the product well away from flammable materials

- Keep all combustible materials (e.g. fabric, wood, paper) at least 10m (40 in.) away from the product.
- Ensure that there is free and unobstructed airflow around the product. Provide a minimum clearance of 150 mm (6 in.) around fans and air vents.
- Do not illuminate surfaces within 10 m (40 ft.) of the product.
- Do not install a fuse that has a higher rating than the one originally installed in the product. Do not bypass fuses.
- Do not stick filters, masks or other materials onto optical components.
- If the fixture seems to be abnormally hot, shows signs of melting or emits smoke, disconnect the fixture from power immediately and allow it to cool. Do not touch the fixture without heatproof safety gloves. Keep the fixture well away from combustible and flammable materials.

**NEVER LOOK DIRECTLY INTO THE LIGHT SOURCE!
RETINA INJURY RISK - MAY INDUCE BLINDNESS!**

Do not point the front of the fixture towards the sun or other strong light sources. The front lens focuses and concentrates light just like a magnifying glass. Strong light can cause internal damage to the fixture, melting components or starting an internal fire within seconds.

To avoid problems from strong light sources:

- Do not expose the front of a fixture to sunlight or any other strong light source. Avoid pointing other high-powered beam lights directly at the fixture.
- Do not focus a light beam from one lighting fixture directly towards another.
- For outdoor applications during daylight, make sure that the front face of any fixture is shielded or points away from the sun, even when not in use.
- Do not expose the product to heat (from other lighting fixtures for example).

2 INSTALLATION

2.1 MOUNTING

Truss installation

- ◆ Keep all combustible materials (e.g. fabric, wood, paper) at least 500 mm (20 in.) away from the product.
- ◆ For overhead use, always install a safety cable that can hold at least 10 times the weight of the fixture.
- ◆ For overhead installation, the fixture must be always secured with a safety wire that can bear at least 10 times the weight of the fixture;
- ◆ Secure the fixture with a safety cable through the rear safety eye and truss as shown..
- ◆ Ensure that the structure (truss) to which you are attaching the fixture is secure

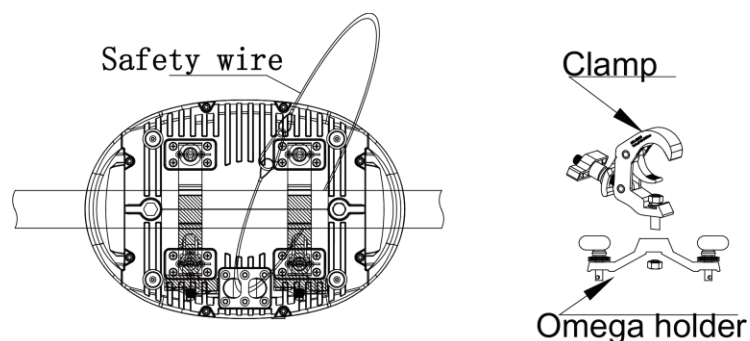

2.2 Fuse replacement

- ◆ Remove the safety cap by a screwdriver.
- ◆ Fetch the old fuse from safety cap.
- ◆ Install a new fuse.
- ◆ Install the safety cap.

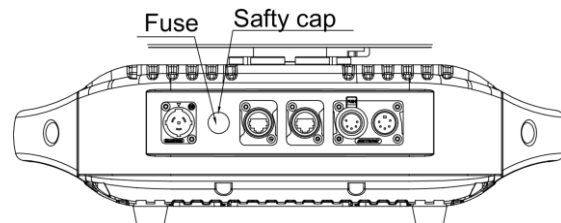

2.3 POWER CONNECTIONS

- ◆ This product has an auto-ranging power supply that can work with an input voltage range of 100–240 VAC, 50/60 Hz.

AC Plug

Connection	Wire (U.S.)	Wire(Europe)	Screw Color
AC Live	Black	Brown	Yellow/Brass
AC Neutral	White	Blue	Silver
AC Ground	Green/Yellow	Green/Yellow	Green

2.4 Data network requirements

- ◆ Connect the DMX512 controller to the units in series. A DMX 512 data link is required in order to control the fixture via DMX. The fixture has 3/5-pin XLR connectors for DMX data input and output.
- ◆ Each unit has 13 DMX channels so the DMX Addresses should increase by increments of 1, (Nx1)+1, (Nx2)+1, (Nx3)+1...
- ◆ Any DMX address in the range from 001 to 512 may be used.
- ◆ Connect the DMX-output of the first fixture in the DMX chain with the DMX-input of the next fixture. Always connect one output with the input of the next fixture until all fixtures are connected.
- ◆ Caution: At the last fixture, the DMX-cable has to be terminated with a terminator. Solder a 120 Ω resistor between Signal (-) and Signal (+) into a 3/5-pin XLR-plug and plug it in the DMX-output of the last fixture.

DMX-output

XLR mounting-sockets

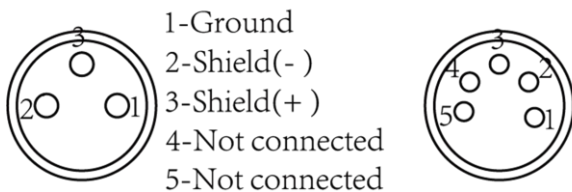

DMX-input

XLR mounting-plugs

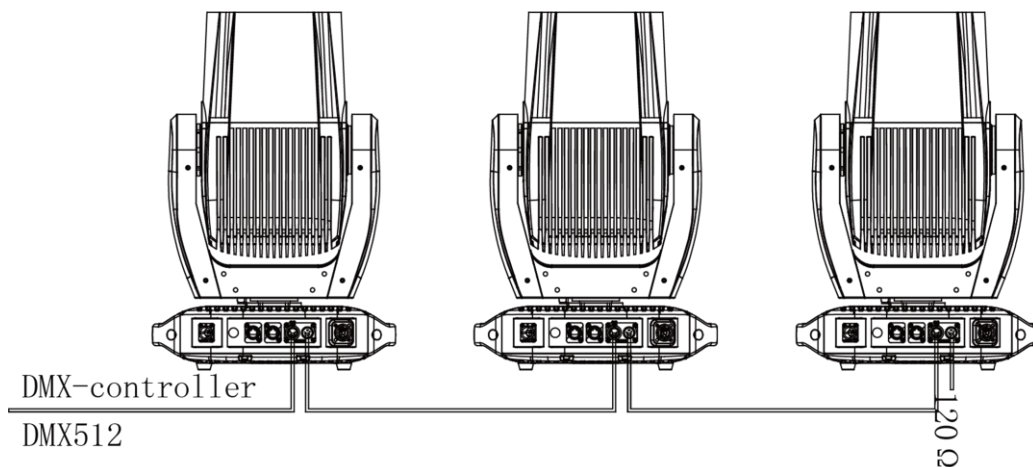
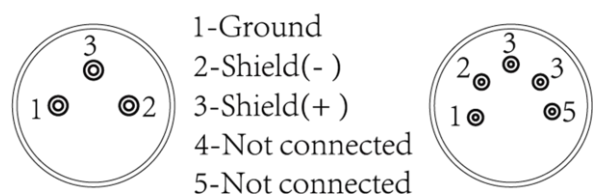

3 FUNCTIONS AND SETTINGS

3.1 DISPLAY OPERATION

- ◆ LEFT: Used to access the menu or to return a previous menu option;
- ◆ RIGHT: Used to select and store the current menu or confirm the current function value or option within a menu;
- ◆ UP: Navigates downwards through the menu list and increases the numeric value when in a function;
- ◆ DOWN: Navigates upwards through the menu list and decreases the numeric value when in a function;
- ◆
- ◆ When the display locked, please unlock the display as below:
 1. Keep pressing BACK around 5sec, until the display shows inset password.
 2. Press “up down up down, enter” to unlock.

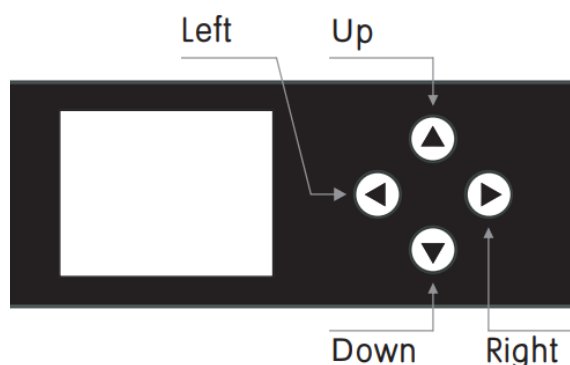

3.2 Menu Map

ADDRESS	001 – 512(Default 001)		DMX address setting	
PERSON	BASIC		Use the menu to select desired channel mode	
	STANDARD (Default)			
	EXTEND			
RUNMODE	DMX512 (Default)		Select Signal	
	ARTNET		Default: DMX512	
	ARTNET TO DMX		ARTNET: Ethernet control	
	sACN		CUSTOM1-2 Set up get into EDIT MENU	
	AUTO		edit	
	CUSTOM1			
	CUSTOM2			
OPTION	PAN INVERT	NORMAL (Default)	PAN moving direction selection	
		INVERT		
	TILT INVERT	NORMAL (Default)	TILT moving direction selection	
		INVERT		
	PERFORM	STUDIO		Fan mode low speed
		POWER		Fast rotation of fan, all power
LIVE (Default)		Automatic rotation of fan		

BLACKOUT	OFF (Default)		Select OFF blackout without delay		
	ON		Select ON Blackout delay 3s		
DIMMER	DIM4 (Default)		Dimming curves OFF (fast) to DIM4 (slow);		
	OFF				
DMX ERROR	SAVE (Default)		Hold after loss of DMX signal		
	BLACK		Blackout after loss of DMX signal		
DISPLAY TIME	On		Display backlight always on		
	30s		Turns off display backlight after 30s/1min /2min of inactivity		
	1min (Default)				
	2min				
DISPLAY LOCK	OFF		Locks display (passcode is <UP>, <DOWN>,<UP>, <DOWN>, <ENTER>)		
	ON (Default)				
LOAD PARA	OFF		Not upload data		
	ON (Default)		Upload data		
SETTING	RECOVERY	****	Restore default factory settings.		
	CLEAN EDIT1	****	Clean customer self-editing scene 1		
	CLEAN EDIT2	****	Clean customer self-editing scene 2		
	WDMX HIDE	NO	YES	Hide wireless mode WDMX reset and signal hide and the default is wired mode only	
YES					
NETWORK	NET SWITCH	2.xxx.xxx.xxx	Net switch off IP mode		
		10.xxx.xxx.xxx	Net switch on IP mode		
	UNIVERS	0-255	Packet group Settings		
	IP MODE	DEFAUL IP	Default IP		
		CUSTOM IP	Customer's IP		
CUSTOM IP	XX.XX.XX.XX	Customer's IP setting			
PT ENCODER	OFF		XY Encoder switch.		
	ON		OFF is close; ON is open.		
FOCUS LIMIT	OFF		Focus limit off		
	ON		Focus limit on		
WDMX RESET	NO		Do not clear the receiver's message.		
	YES		Clear the receiver's message		
SIGNAL	ONLY XLRDMX		ONLY XLR is wire only		
	XLRDMX FIRST		XLR FIRST is wire first		
	ONLY WDMX		ONLY WDMX is wireless only		
	WDMX FIRST		WDMX FIRS is wireless first		
	WDMX TO XLRDMX		WDMX TO DMX is wireless to wired		
EDIT	EDIT 1-2	STEP 1-30	PAN	0-255	Edit the custom programs1-30 Select play 【EDIT 1】 in RUNMOEDE CUSTOM 1; Select play 【EDIT 2】 in RUNMOEDE CUSTOM 2
			TILT	0-255	
			PT SPEED	0-255	
			CTO	0-255	

			COLOR	0-255	
			FIXED GOBO	0-255	
			PRISM 1	0-255	
			PRISM 2	0-255	
			FOCUS	0-255	
			DIMMER	0-255	
			STROBE	0-25	
			TIME	0-255	
			USE	YES/NO	Select YES to run the steps user need.
MANUAL	AUTO TEST				
	CHANNEL	PAN	0-255		Manual control channel
		TILT	0-255		
		PT SPEED	0-255		
		CTO	0-255		
		COLOR	0-255		
		FIXED GOBO	0-255		
		PRISM 1	0-255		
		PRISM 2	0-255		
		FOCUS	0-255		
		DIMMER	0-255		
	STROBE	0-25			
	DEBUG HIDE	YES			Factory testing mode. All stepper motors are not controlled by signal, It only works again after the reset.
		NO			
RESET	ALL RESET			Select Yes/No to carry out all reset	
	PT RESET			Select Yes/No to carry out P/T reset	
	COLOR SYSTEM			COLOR/CTO/ GOBO reset	
	OTHER			Prism1/Prism2/Focus reset	
INFO	FIXTURE HOURS				Hours of fixture use
	LED USE HOURS				LED use time
	TEMPERATURE				LED temperature
	VERSION				Software versions
	NETWORK				Check network parameter
	RDM	UID	0x388Axxxxxxx		Check fixture's ID
		LABEL	NEPTUNE SUPER BEAM		Check fixture's LABEL
	SYSTEM ERROR	MEMORY IC			Memory IC
		ANGLESENSOR			Angle Sensor
		PAN SENSOR			Pan Sensor
PAN ENCODER			Pan Encoder		
PAN DRIVEIC			Pan Drive IC		

		TILT SENSOR		Tilt Sensor
		TILT ENCODER		Tilt Encoder
		TILT DRIVEIC		Tilt Drive IC
		TEMPERATURE		Temperature
		CTO		CTO reset
		COLOR RESET		Color reset
		FIXED GOBO RESET		gobo reset
		PRISM 1 RESET		Prism 1 reset
		PRISM 2 RESET		Prism 2 reset
		FOCUS RESET		Focus reset
SERVICE	****	PAN	±127	Pan position fine adjustment
		TILT	±127	Tilt position fine adjustment
		CTO	±127	CTO position fine adjustment
		COLOR	±127	Color position fine adjustment
		FIXED GOBO	±127	Gobo position fine adjustment
		PRISM 1	±127	Prism1 position fine adjustment
		PRISM 2	±127	Prism2 position fine adjustment
		FOCUS	±127	Focus position fine adjustment

All passwords of this product are <UP>, <DOWN>,<UP>, <DOWN>, <ENTER>)

4 USING A DMX512 CONTROLLER

4.1 DMX CONTROL

BASIC (12CH)	STANDARD (16CH)	Extend (18CH)	Value	Function
1	1	1	000-255	PAN 0-540°
-	2	2	000-255	PAN FINE
2	3	3	000-255	TILT 0-270°
-	4	4	000-255	TILT FINE
3	5	5	000-255	PT Speed
4	6	6	CTO	
			0-10	WHITE
			11-127	CTO
			128-244	CTB
5	7	7	COLOR WHEEL 19+1	
			0-7	WHITE
			8-10	COLOR 1
			11-13	COLOR 2
			14-16	COLOR 3
			17-19	COLOR 4
			20-22	COLOR 5
			23-25	COLOR 6
			26-28	COLOR 7
			29-31	COLOR 8
			32-34	COLOR 9
			35-37	COLOR 10
			38-40	COLOR 11
			41-43	COLOR 12
			44-46	COLOR 13
			47-49	COLOR 14
			50-52	COLOR 15
			53-55	COLOR 16
			56-58	COLOR 17
			59-61	COLOR 18
62-64	COLOR 19			
65-191	COLOR WHELL1 0-360°			
192-222	COLOR WHELL1 RAINBOW EFFECT(SPEED 100%->1)			
223-224	STOP			
225-255	COLOR WHELL1 RAINBOW EFFECT(SPEED 1->100%)			

-	-	8	000-255	COLOR WHEEL FINE
6	8	9	FIXED GOBO WHEEL 29+1	
			0-10	WHITE
			11-12	FIXED GOBO WHEEL 1
			13-14	FIXED GOBO WHEEL 2
			15-16	FIXED GOBO WHEEL 3
			17-18	FIXED GOBO WHEEL 4
			19-20	FIXED GOBO WHEEL 5
			21-22	FIXED GOBO WHEEL 6
			23-24	FIXED GOBO WHEEL 7
			25-26	FIXED GOBO WHEEL 8
			27-28	FIXED GOBO WHEEL 9
			29-30	FIXED GOBO WHEEL 10
			31-32	FIXED GOBO WHEEL 11
			33-34	FIXED GOBO WHEEL 12
			35-36	FIXED GOBO WHEEL 13
			37-38	FIXED GOBO WHEEL 14
			39-40	FIXED GOBO WHEEL 15
			41-42	FIXED GOBO WHEEL 16
			43-44	FIXED GOBO WHEEL 17
			45-46	FIXED GOBO WHEEL 18
			47-48	FIXED GOBO WHEEL 19
			49-50	FIXED GOBO WHEEL 20
			51-52	FIXED GOBO WHEEL 21
			53-54	FIXED GOBO WHEEL 22
			55-56	FIXED GOBO WHEEL 23
			57-58	FIXED GOBO WHEEL 24
			59-60	FIXED GOBO WHEEL 25
			61-62	FIXED GOBO WHEEL 26
			63-64	FIXED GOBO WHEEL 27
			65-66	FIXED GOBO WHEEL 28
			67-68	FIXED GOBO WHEEL 29
			69-72	FIXED GOBO WHEEL 1 SHAKE (SPEED 1 → 100%)
73-76	FIXED GOBO WHEEL 2 SHAKE (SPEED 1 → 100%)			
77-80	FIXED GOBO WHEEL 3 SHAKE (SPEED 1 → 100%)			
81-84	FIXED GOBO WHEEL 4 SHAKE (SPEED 1 → 100%)			
85-88	FIXED GOBO WHEEL 5 SHAKE (SPEED 1 → 100%)			
89-92	FIXED GOBO WHEEL 6 SHAKE (SPEED 1 → 100%)			
93-96	FIXED GOBO WHEEL 7 SHAKE (SPEED 1 → 100%)			
97-100	FIXED GOBO WHEEL 8 SHAKE (SPEED 1 → 100%)			

			101-104	FIXED GOBO WHEEL 9 SHAKE (SPEED 1 → 100%)
			105-108	FIXED GOBO WHEEL 10 SHAKE (SPEED 1 → 100%)
			109-112	FIXED GOBO WHEEL 11 SHAKE (SPEED 1 → 100%)
			113-116	FIXED GOBO WHEEL 12 SHAKE (SPEED 1 → 100%)
			117-120	FIXED GOBO WHEEL 13 SHAKE (SPEED 1 → 100%)
			121-124	FIXED GOBO WHEEL 14 SHAKE (SPEED 1 → 100%)
			125-128	FIXED GOBO WHEEL 15 SHAKE (SPEED 1 → 100%)
			129-132	FIXED GOBO WHEEL 16 SHAKE (SPEED 1 → 100%)
			133-136	FIXED GOBO WHEEL 17 SHAKE (SPEED 1 → 100%)
			137-140	FIXED GOBO WHEEL 18 SHAKE (SPEED 1 → 100%)
			141-144	FIXED GOBO WHEEL 19 SHAKE (SPEED 1 → 100%)
			145-148	FIXED GOBO WHEEL 20 SHAKE (SPEED 1 → 100%)
			149-152	FIXED GOBO WHEEL 21 SHAKE (SPEED 1 → 100%)
			153-156	FIXED GOBO WHEEL 22 SHAKE (SPEED 1 → 100%)
			157-160	FIXED GOBO WHEEL 23 SHAKE (SPEED 1 → 100%)
			161-164	FIXED GOBO WHEEL 24 SHAKE (SPEED 1 → 100%)
			165-168	FIXED GOBO WHEEL 25 SHAKE (SPEED 1 → 100%)
			169-172	FIXED GOBO WHEEL 26 SHAKE (SPEED 1 → 100%)
			173-176	FIXED GOBO WHEEL 27 SHAKE (SPEED 1 → 100%)
			177-180	FIXED GOBO WHEEL 28 SHAKE (SPEED 1 → 100%)
			181-184	FIXED GOBO WHEEL 29 SHAKE (SPEED 1 → 100%)
			185-188	STOP WATER EFFECT
			189-219	STATIC GOBO JUMPING WATER EFFECT (SPEED 100 → 1%)
			220-224	STOP WATER EFFECT
			225-255	STATIC GOBO FLOWING WATER EFFECT (SPEED 1 → 100%)
-	-	10	000-255	FIXED GOBO WHEEL FINE
7	9	11	PRISM 1	
			0-10	WHITE
			11-145	PRISM INSERT AND ADJUST THE ANGLE (0 → 360°)
			146-150	STOP
			151-200	PRISM INSERT AND POSITIVE ROTATION (SPEED 100% → 1)
			201-205	STOP ROTATION
			206-255	PRISM INSERT AND REVERSE ROTATION (SPEED 1 → 100%)
8	10	12	PRISM 2	
			0-10	WHITE
			11-145	PRISM INSERT AND ADJUST THE ANGLE (0 → 360°)
			146-150	STOP
			151-200	PRISM INSERT AND POSITIVE ROTATION (SPEED 100% → 1)
			201-205	STOP ROTATION
			206-255	PRISM INSERT AND REVERSE ROTATION (SPEED 1 → 100%)

9	11	13	000-255	FOCUS
-	12	14	000-255	FOCUS FINE
10	13	15	000-255	DIMMER
-	14	16	000-255	DIMMER FINE
11	15	17	STROBE	
			0-9	NO FUNCTION
			10-99	STROBE (FROM SLOW TO FAST)
			100-109	NO FUNCTION
			110-179	LIGHTNING STROBE
			180-189	NO FUNCTION
			190-255	RANDOM SROBE
12	16	18	CONTROL (EXECUTE AFTER 3 SECONDS)	
			0-10	NO FUNCTION
			11-20	PAN/TILT BLACK ACTIVATED
			21-30	PAN/TILT BLACK DEACTIVATED
			31-40	PAN INVERT
			41-50	TILT INVERT
			51-60	PAN/TILT INVERT OFF
			61-70	STUDIO
			71-80	POWER
			81-90	LIVE
			91-100	RESERVED
			101-110	DIM4
			111-120	OFF
			121-200	RESERVED
			201-210	ALL RESET
			211-220	XY RESET
			221-230	COLOR\GOBO SYSTEM RESET
231-240	FOCUS RESET			
241-255	RESERVED			